

REV	LTR	DESCRIPTION	DATE	APPROVED
AO			20160406	

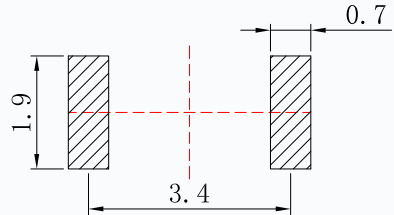

Remarks:

1. Rated current, Voltage: DC 12V 50mA
2. Contact resistance: $\leq 100m\Omega$
3. Insulation resistance: $\geq 100M\Omega$
4. The intensity of operations: $300 \pm 50gf$
5. Life requirements: 100000 times
6. Withstand voltage: AC250V 1 minute
7. All materials comply with RoHS standards

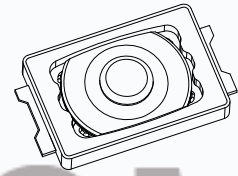
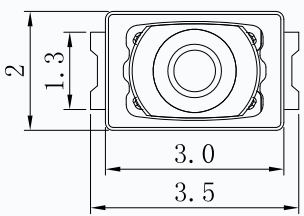
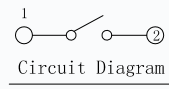
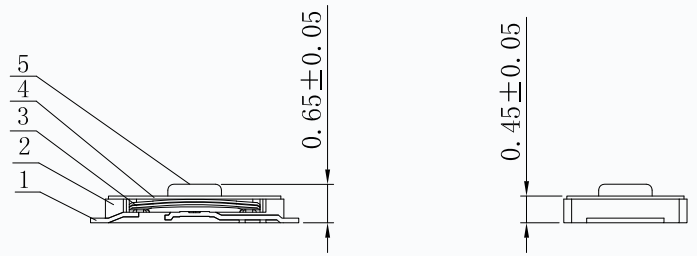
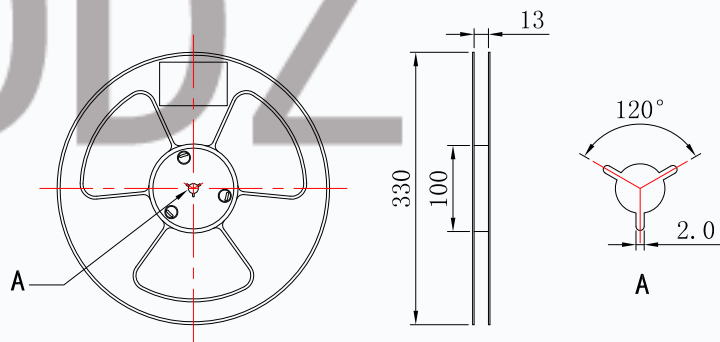
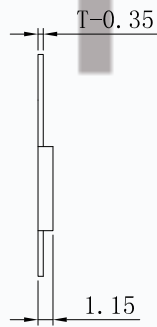
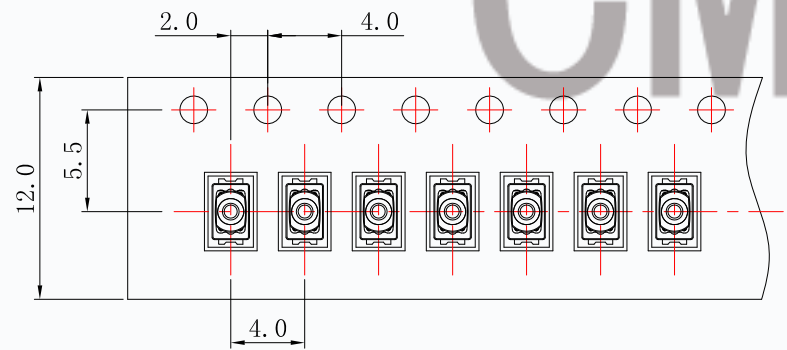

Remarks:

- 1, The number of tapes per volume is 10000 PCS;
- 2, Braiding process, can not be caused by carrying half crushed;
- 3, Pay attention to the direction of the tape, with a clockwise direction out of the carrier tape, with a hole in the top or right

NO.	PART NAME	MATERIAL	QTY	FINISHING
5	Button	Polyimide	1	Yellow
4	Paster	Polyimide	1	Yellow
3	Shrapnel	SUS	2	Ag Plating
2	Housing	LCP	1	Black
1	Terminal	Phosphor copper	2	Ag Plating

TOLERANCE		NAME(INTENDED USE) CUSTOMER DRAWING		CMTDZ 东莞市田都科技有限公司 Dongguan Tiandu Technology Co., Ltd.		
X.X ±0.30	X.' ±10'	PART NO.		Tact switch		
.XX ±0.20	.X' ± 8'	DESIGN:		TITLE: T6-2030BS		
.XXX ±0.10	.XX' ± 5'	MATERILA		CHED:		
UNITS	mm	FINISH		APPD:		
				SCALE SHEET REV. SCALE SHEET REV.		