

REV.	ECN NO.	DESCRIPTION	DRAW	CHECK	APPD.	DATE
A0	N/A	NEW DWG.				2016-10-28

NOTES:

SPECIFICATION:

1. CURRENT RATING: 5A MAX
2. VOLTAGE: 100 VAC
3. TEMPERATURE RANGE: -30 °C ~ 85 °C
4. CONTACT RESISTANCE: 40 MILLIONHM MAX
5. INSULATION RESISTANCE: 100 MEGOHMS MIN.
6. INSERTION FORCE : 5N~20N
7. UNMATING FORCE: 8N~20N
8. DURABILITY: 10,000 CYCLES

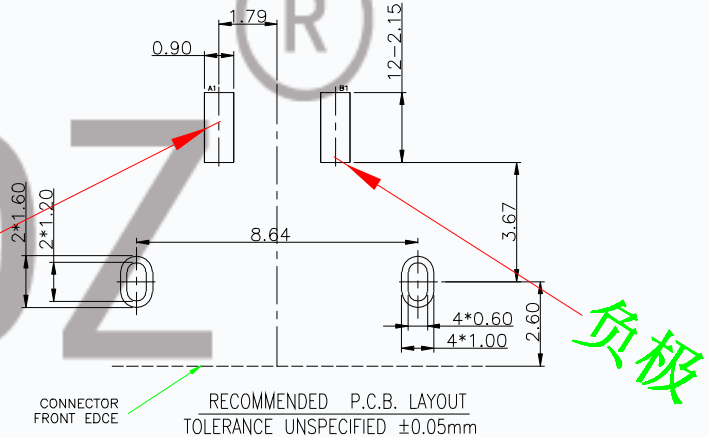
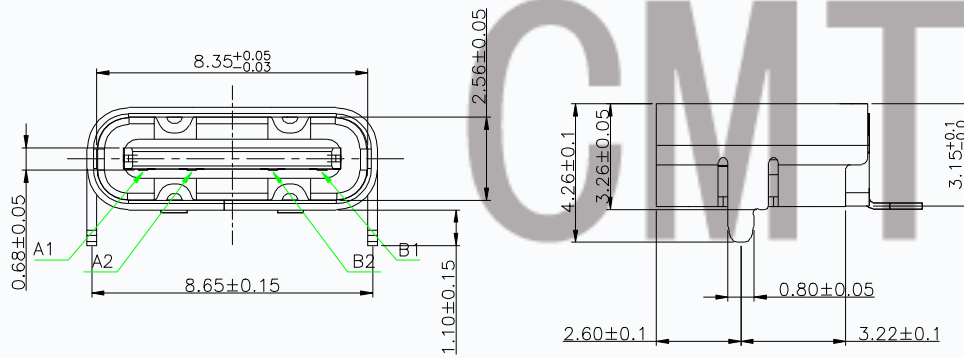
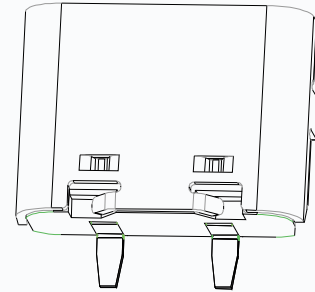
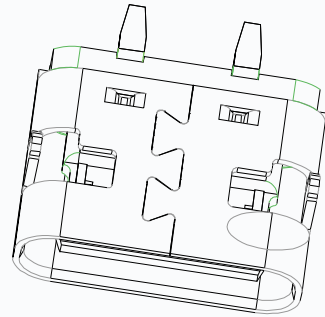
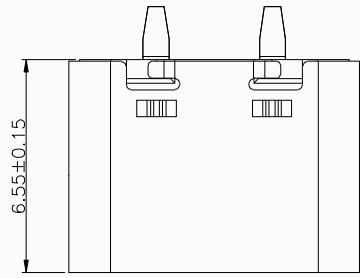

CONNECTOR FRONT EDGE  
RECOMMENDED P.C.B. LAYOUT  
TOLERANCE UNSPECIFIED ±0.05mm

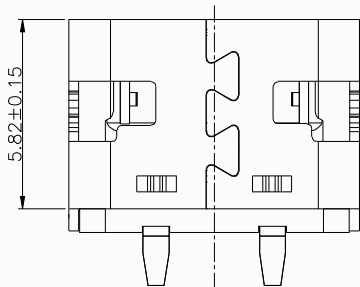

A1	GND	B1	GND
PIN	SIGNAL NAME	PIN	SIGNAL NAME

6	SHELL	STAINLESS STEEL	NI/SN Plated	1PCS
5	SHIELDING PLATE	STAINLESS STEEL	---	1PCS
4	MD	HIGH TEMPERATURE PLASTIC	BLACK	1PCS
3	CONTACT	COPPER ALLOY	Au/Ni Plated	1SET
2	CONTACT	COPPER ALLOY	Au/Ni Plated	1SET
1	HOUSING	HIGH TEMPERATURE PLASTIC	BLACK	1PCS
NO.	DESCRIPTION	MATERIAL	REMARKS	QTY

UNITS mm	SCALE 1:1	REV. A0	SHEET 1 OF 1	<b>CMTDDZ 东莞市田都科技有限公司</b> <b>Dongguan TianDu Technology Co. Ltd.</b>	
		DATE	TITLE USB C TYPE 母座单排2PIN板上SMT		
GENERAL TOLERANCE 0. ±0.35 0.0 ±0.35 0.00 ±0.25 0.° ±4° 0.0° ±3°		DR.	MAT'L SEE TABLE		FINISH SEE TABLE
		CHK.	DWG.NO. T11-02BS02S		PART NO.
		APPD.	A		SIZE A4