

REV.	DESCRIPTION	NAME	DATE
A	NEWS ISSUE	ERIC	2020/07/23
B	Change frame	ERIC	2021/06/05

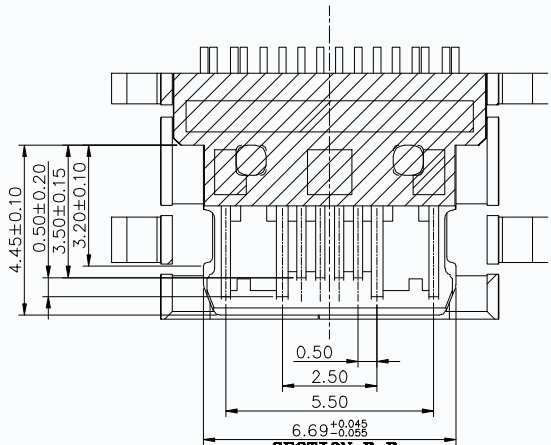

SECTION B-B  
SCALE 1:1

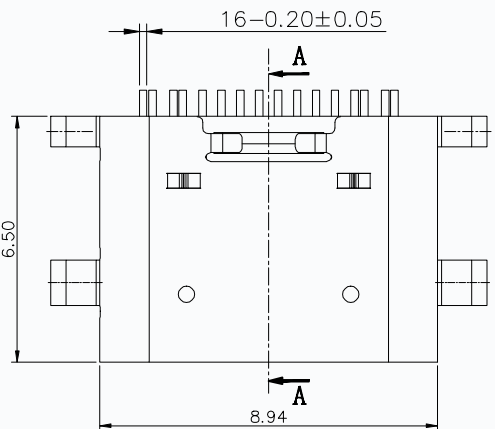
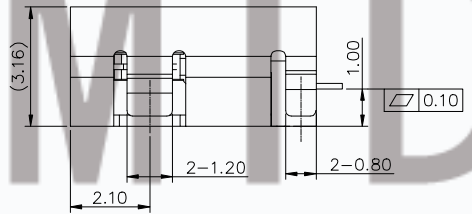
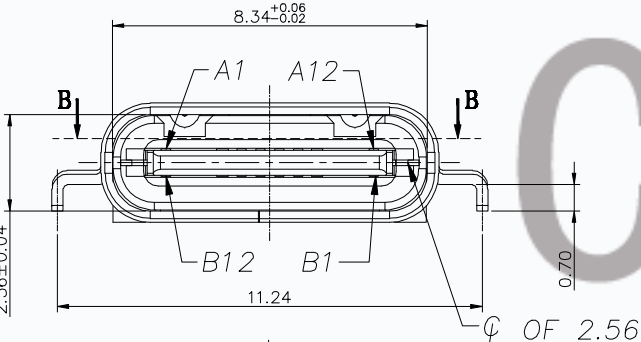

SECTION B-B  
SCALE 1:1

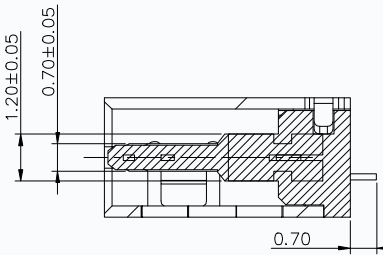
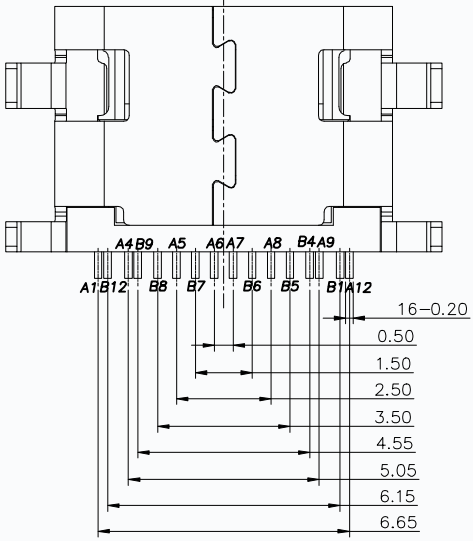

SECTION B-B  
SCALE 1:1

NOTE:

- MATERIAL SPECIFICATION:
  - HOUSING: HIGH TEMPERATURE RESISTANT PLASTIC, UL94 V-0.
  - CONTACTS: COPPER ALLOY
  - MID PLATE: STAINLESS STEEL
  - SHELL: STAINLESS STEEL
- PLATING SPECIFICATION:
  - CONTACTS:
    - Ni 50u" MIN. UNDER PLATED OVER ALL.
    - Au PLATED ON THE FUNCTIONAL AREA OF CONTACT. (GOLD PLATING THICKNESS FOLLOW THE P/N)
    - GOLD FLASH PLATING ON SOLDER AREA
  - FRONT SHELL:
    - Ni 30u" MIN. UNDER PLATED OVER ALL.
- MECHANICAL PERFORMANCE,
  - INSERTION FORCE: 0.5~2.0kgf.
  - REMOVAL FORCE: 0.8kgf~2.0kgf.
  - DURABILITY: 10000 CYCLES.
- ELECTRICAL PERFORMANCE,
  - CURRENT RATING: 6A  
VOLTAGE RATING: 20V
  - INSULATION RESISTANCE: 100MΩ PER MIN.
  - DIELECTRIC WITHSTAND VOLTAGE, AC 100V FOR 1 MINUTE.
  - LOW CONTACT RESISTANCE: INITIAL 40MΩ
- ENVIRONMENTAL PERFORMANCE:
  - OPERATING TEMPERATURE: -30°C~+80°C.
- IR REFLOW:
  - THE PEAK TEMPERATURE ON THE BOARD SHALL BE MAINTAINED FOR 10 SECONDS AT 260°C.

TOLERANCE UNSPECIFIED .0 ±0.35 .00 ±0.25 .000 ±0.15 X ° ±2.00° ASSEMBLY DRAWING		<b>CMTDDZ 东莞市田都科技有限公司</b> Dongguan TianDu Technology Co. Ltd.		
TITLE: USB TYPE C 16PIN, L-6.50mm 沉板1.00mm—客户图		SIZE: A4	UNIT: mm.	PART. NO: T11-16CB06-1.0H-3-6.5L
DRAWN DATE ERIC 2021/06/05	CHECKED DATE ERIC 2021/06/05	APPROVED DATE JEFF 2021/06/05	SCALE: 1:1 DWG PATH	PROJECTION REV.: B PATH 1/3

REV.	DESCRIPTION	NAME	DATE
A	NEWS ISSUE	ERIC	2020/07/23
B	Change frame	ERIC	2021/06/05

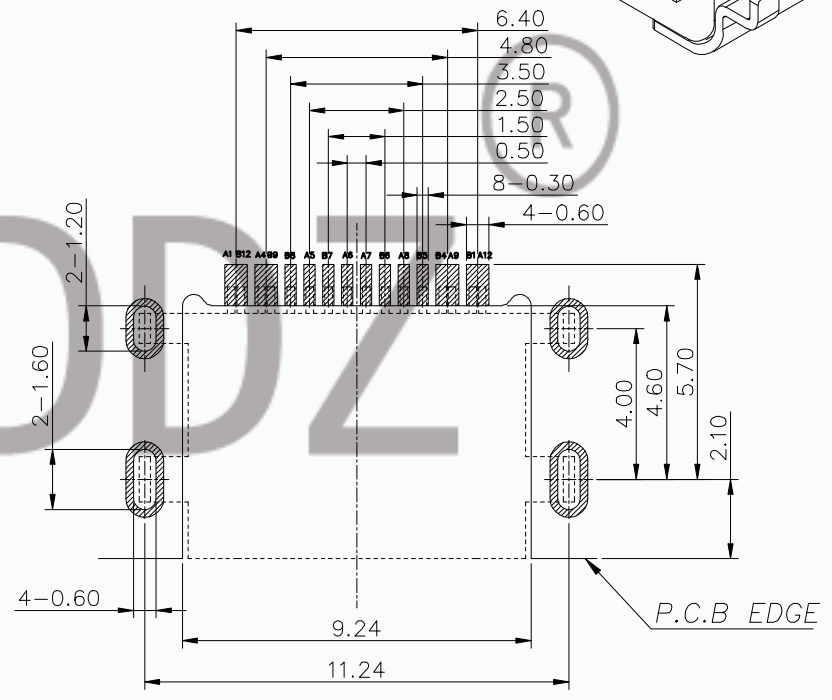
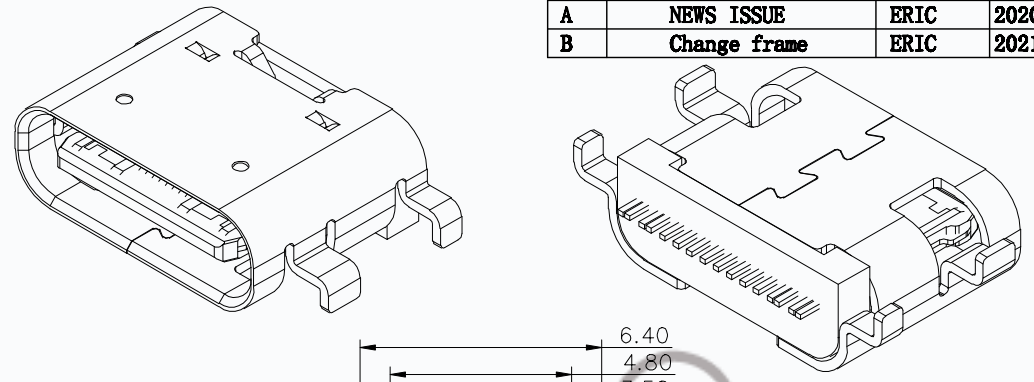

**USB TYPE-C PIN ASSIGNMENTS**

PIN NUMBER	SIGNAL NAME	PIN NUMBER	SIGNAL NAME
A1	GND	B12	GND
A4	VBUS	B9	VBUS
A5	CC1	B8	SBU2
A6	Dp1	B7	Dn2
A7	Dn1	B6	Dp2
A8	SBU1	B5	CC2
A9	VBUS	B4	VBUS
A12	GND	B1	GND

RECOMMEND P.C.B LAYOUT (COMPONENT SIDE)  
TOLERANCE FOR PCB LAYOUT IS ± 0.05

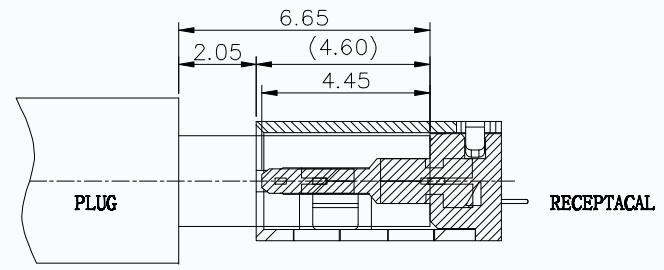

TOLERANCE UNSPECIFIED		CMTDDZ 东莞市田都科技有限公司 Dongguan TianDu Technology Co. Ltd.					
.0	±0.35	TITLE: USB TYPE C 16PIN, L-6.50mm 沉板1.00mm—客户图					
.00	±0.25						
.000	±0.15						
X *	±2.00*						
ASSEMBLY DRAWING		DRAWN DATE	ERIC 2021/06/05	SIZE:A4	UNIT:mm	PART.NO:	T11-16CB06-1.0H-3-6.5L
		CHECKED DATE	ERIC 2021/06/05	SCALE:	1:1	PROJECTION	REV.: B
		APPROVED DATE	JEFF 2021/06/05	DWG	PATH	T11-16CB06-1.0H-3-6.5L	PATH 2/3

REV.	DESCRIPTION	NAME	DATE
A	NEWS ISSUE	ERIC	2020/07/23
B	Change frame	ERIC	2021/06/05

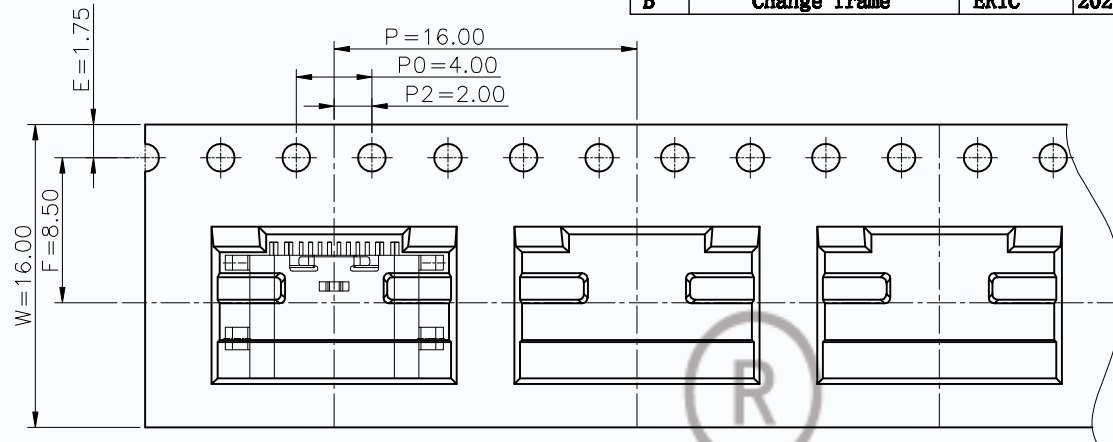
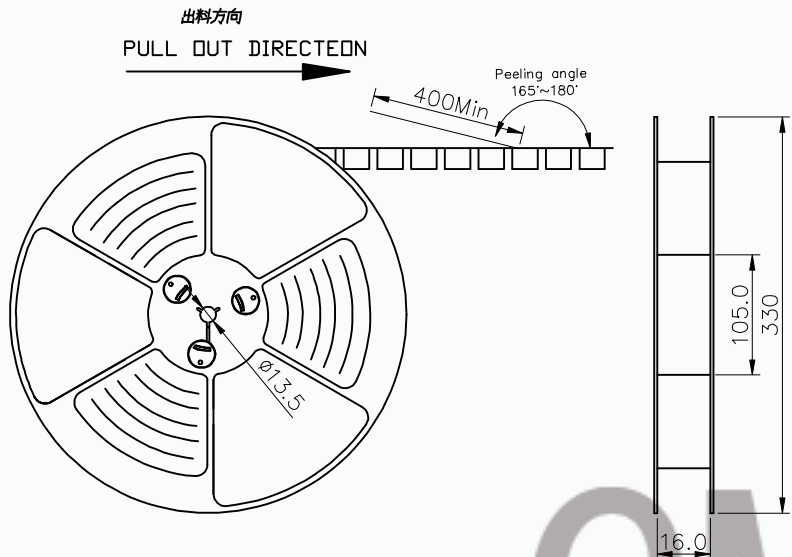

NOTES

1. 帶子引導長度

LEAD TAPE LENGTH

出料方向

PULL OUT DIRECTION

出料方向

PULL OUT DIRECTION

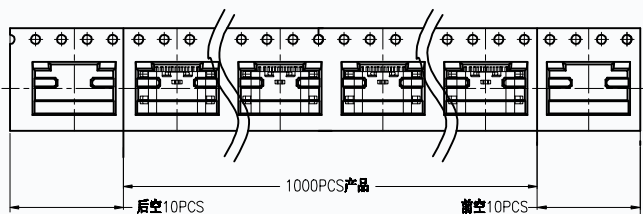

2. 上帶 剝力為: 0.1~1.3N(10.2gf~130gf)

PEELING OFF FORCE OF TOP TAPE: 0.1~1.3N(10.2gf~130gf)

出貨運輸過程中一定注意:

THIS REQUIREMENT SHOULD BE APPLIED AT SHIPMENT;

卷帶在運輸過程中不能散開

PEELING OFF SHOULD NOT BE ALLOWED DURING TRANSPORTATION

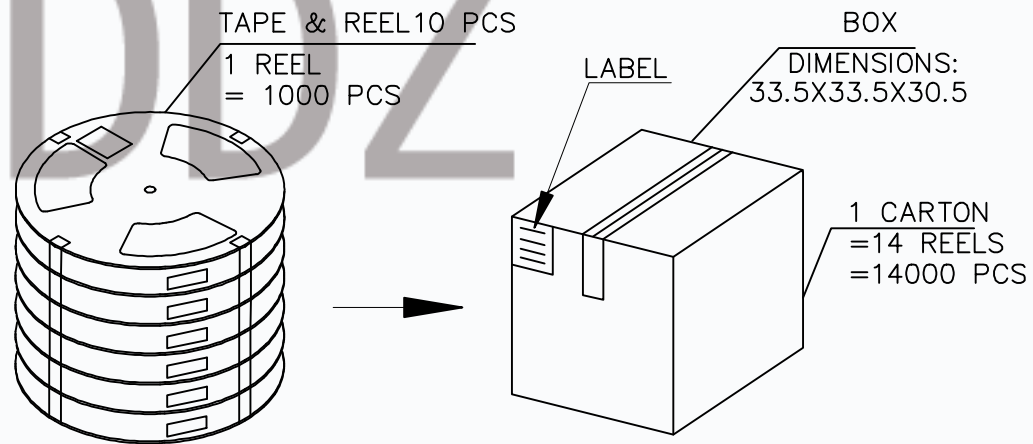

TOLERANCE UNSPECIFIED		CMTDDZ 东莞市田都科技有限公司	
.0	±0.35	Dongguan TianDu Technology Co. Ltd.	
.00	±0.25	TITLE: USB TYPE C 16PIN, L-6.50mm	
.000	±0.15	沉板1.00mm-客户图	
X°	±2.00°	SIZE: A4	UNIT: mm. PART. NO: T11-16CB06-1.0H-3-6.5L
ASSEMBLY DRAWING		CHECKED DATE: ERIC 2021/06/05	SCALE: 1:1 PROJECTION:  REV.: B
		DRAWN DATE: ERIC 2021/06/05	APPROVED DATE: JEFF 2021/06/05
		DWG PATH: T11-16CB06-1.0H-3-6.5L	PATH 3/3

包裝明細表 (The detail of the packing) Carton						
產品料號 (Product No.)	包裝容量 (Packing Capacity)			重量 Weight (Kg)		
	pcs/box	boxs/Carton	Pcs/Box	N.W./Pcs	N.W./Box	G.W./Box
T11-16CB06-1.0H-3-6.5L	1000	14	14000	—	—	—