

1	2	3	4	5	6	7	8
项目 Mapx	设计内容 Modification	日期 Date	修改人 Draw	核准 Approve			

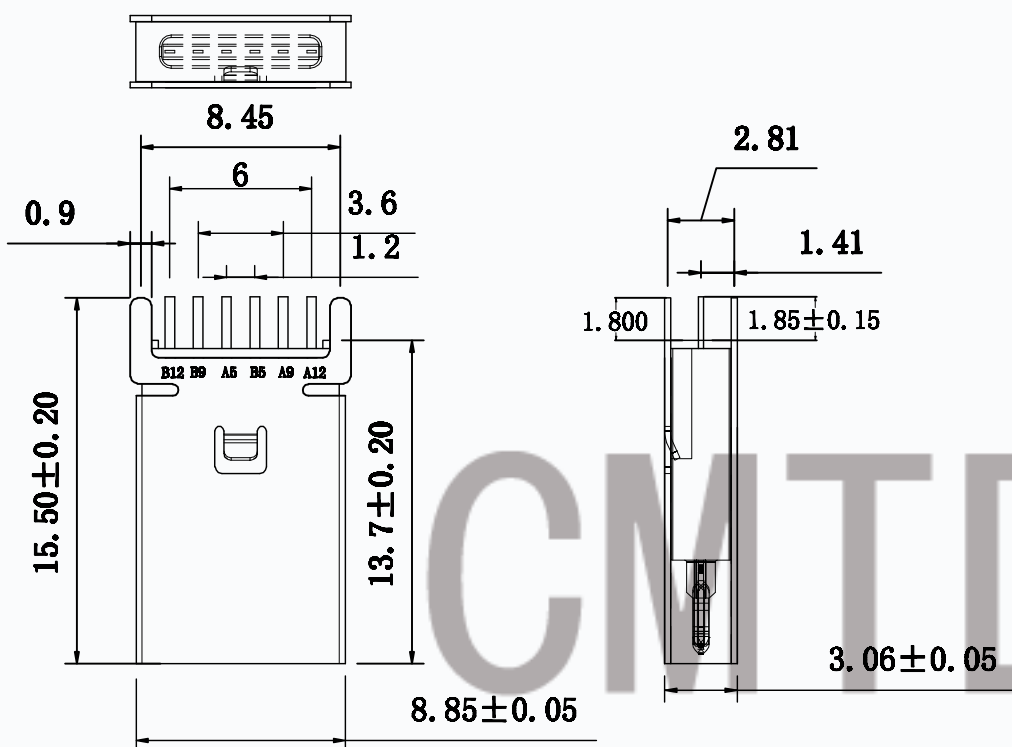

规格说明: Specifications:

电气特性: Electrical:

1. 额定电流: Current Rating
3.0A/contact terminal
2. 额定电压: Voltage Rating
30V DC
3. 接触电阻: Contact Resistance
30 milliohms MAX
4. 耐电压: Dielectric Withstanding Voltage:
100 V AC AT Sea Level
5. 绝缘电阻: Insulation Resistance:
1000MEGA ohms MIN

物理性能: Mechanical:

1. 插拔力: Connector Mate and Unmate Force
Mate force: 3.57kgf(MAX)
Unmate force: 1.02kgf(MIN)

原材料: Material:

1. 塑胶: Housing: LCP+30%GF
2. 端子: Contact: Copper Alloy C2680-EH
3. 外壳: Shell: Copper Alloy C201 不锈钢

电镀: Finish:

1. 端子: Contact: Plated Gold in Mating Area;
Tin On Solder Tails
端子四周镀30-50U"(MIN)锡, 镀金区域镀金1U"
2. 外壳: Shell:
不锈钢壳四周镀80U"(MIN)镍底,
Nickel Plating

A12	GND	B12	GND
A9	VBUS	B9	VBUS
A5	CC1	B5	CC2
PIN	SIGNAL NAME	PIN	SIGNAL NAME

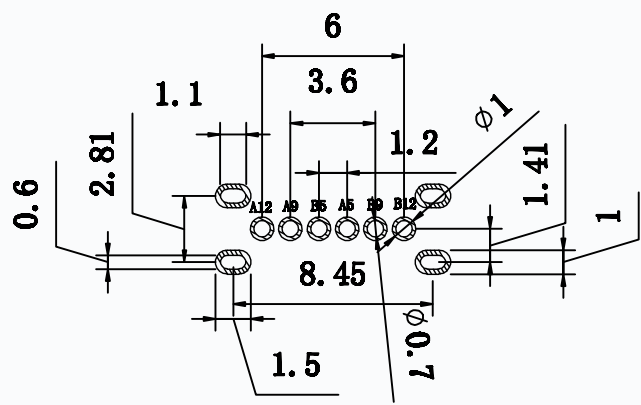

RECOMMENDED P.C.B. LAYOUT
TOLERANCE UNSPECIFIED ±0.05mm

成品图 MANUFACTURE DWG		CMTDDZ 东莞市田都科技有限公司 Dongguan TianDu Technology Co. Ltd.					
公差一览表 TOLERANCE UNLESS OTHERWISE		日期 DATE	单位 UNIT	MM	制图 DRAWING	DWG NO.	T11-06LC05-13.7H
.X±0.20	.X±5'	审核 CHECKED	比例 SCALE	1:1	设计 DESIGN	品名 NAME	TYPEC 6p 180MHz
XX±0.10	.X±2'	核准 APPROVE	角法 VIEW	⊕		版本 VER	A0
XXX±0.05	.XX±1'					页数 SHEET	003