

版次	变更摘要	日期	序号	品名	材质
0	新产品发行	2019/06/15	①	PH2.0直针WTB胶芯	PA66 UL94V-0 米色 白色 红色
			②	PH2.0弯针WTB端子	铜合金/表面镀锡

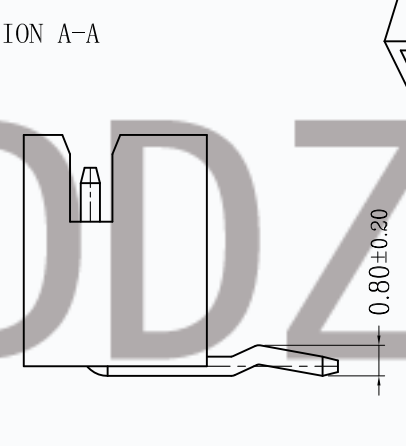
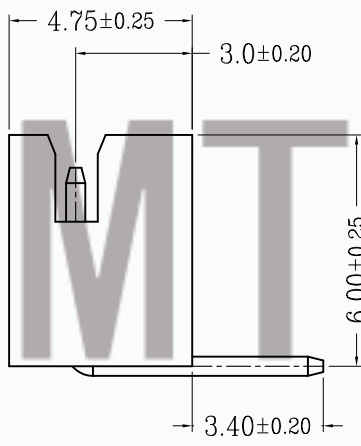
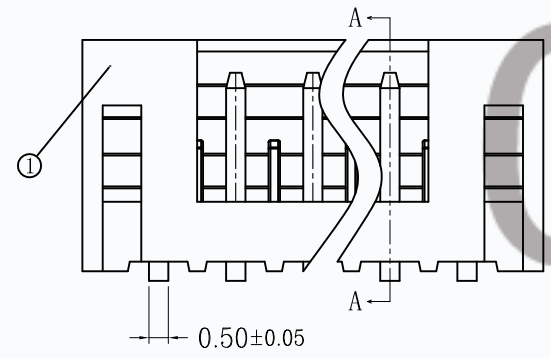
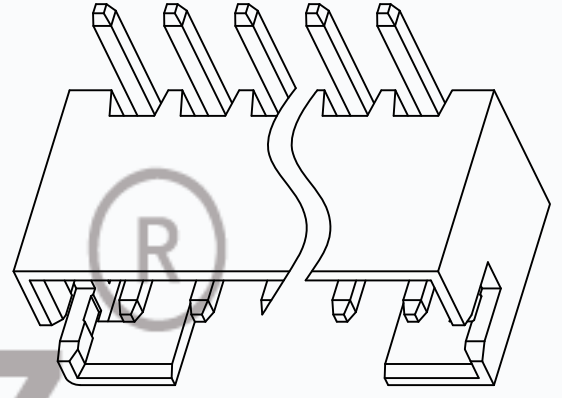
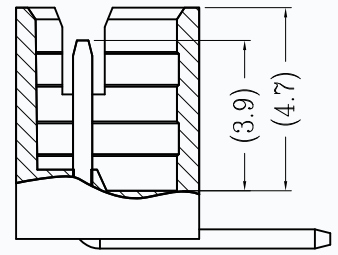
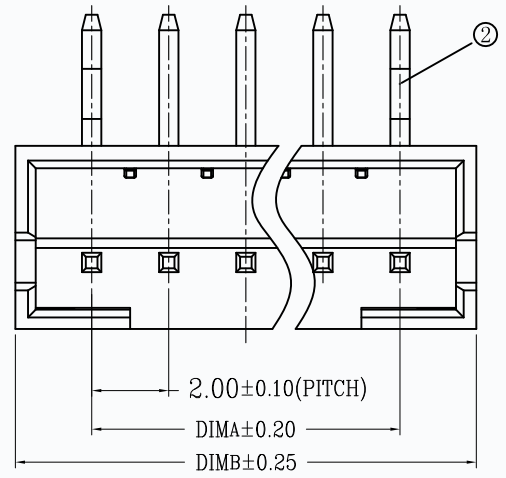

TYPE 1 (无K脚)

TYPE 2 (打K脚)

技术指标 (Technical Index):

1. 工作温度 (Temperature range): -25° C~85° C.
2. 额定电压 (Rated voltage): 250V DC/AC(rms).
3. 额定电流 (Rated current): 2.0A.
4. 接触电阻 (Contact resistance): ≤25mΩ.
5. 耐压值 (Withstanding voltage): 500V AC/minute.
6. 绝缘电阻 (Insulation resistance): ≥1000MΩ.
7. 产品料号 (Product material No.):

T19-200MW-*** * -***	DP	DIP型无K脚, 高温料无LOGO
	D9	DIP型无K脚, 低温料无LOGO
	DK	DIP型打K脚, 高温料无LOGO
	K9	DIP型打K脚, 低温料无LOGO

NO OF CKT (产品PIN数) Packing (包装方式)
Plating (电镀方式) P: PE袋装/盒装
4: 端子全亮锡

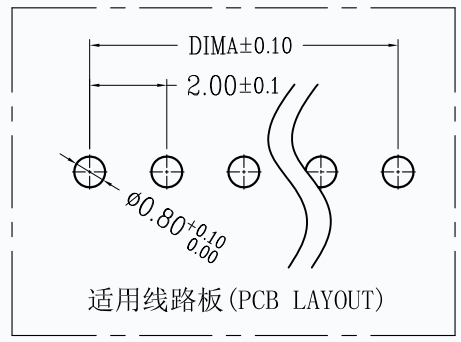

一般公差 (TOLERANCE)
X ±.50 XX ±.10
X ±.20 XXX ±.05
ANGLES ±1°

CKT	A	B	CKT	A	B
2	2.0	6.0	12	22.0	26.0
3	4.0	8.0	13	24.0	28.0
4	6.0	10.0	14	26.0	30.0
5	8.0	12.0	15	28.0	32.0
6	10.0	14.0	16	30.0	34.0
7	12.0	16.0	17	32.0	36.0
8	14.0	18.0	18	34.0	38.0
9	16.0	20.0	19	36.0	40.0
10	18.0	22.0	20	38.0	42.0
11	20.0	24.0			

CMTDDZ 东莞市田都科技有限公司
Dongguan TianDu Technology Co. Ltd.

品名 (TITLE)	PH2.0弯针-WTB	制图 (DR)	ERIC
料号 (DWG.NO)	T19-200MW-****-***	校对 (CHKD)	
比例 (SCALE)	1:1	审核 (APPD)	
单位 (UNITS)	mm	张数 (SHEET)	1 OF 1
		SIZE	A4
		REV	A