

GP Component

REV.	ECN NO.	LOCATIONS	DESCRIPTION	DATE	DESIGN
A0			原始版本(INITIAL EDITION)	2020.12.15	ERIC

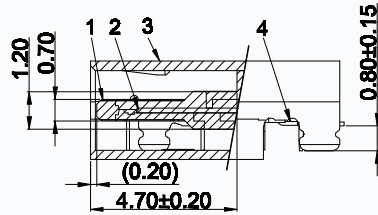
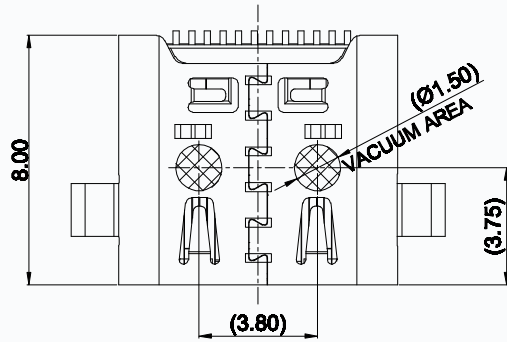

NOTE/注释:

1. SPECIFICATION/规格:

- 1.1 Rated current (额定电流) : 5.0 A
- 1.2 Voltage rating (额定电压) : 5V AC
- 1.3 Contact Resistance (接触阻抗) : 40 m Ω Max.
- 1.4 Insulation Resistance (绝缘阻抗) : 100MΩ Min.
- 1.5 Withstanding voltage (耐电压) : 100 VAC/minute
- 1.6 Mating force (插入力) : 5~20N .
- 1.7 Unmating force (拔出力) : 8~20N.
- 1.8 Durability Cycle(寿命循环):10,000 cycle
- 1.9 Operating temperature (工作温度) : -40°~+85°

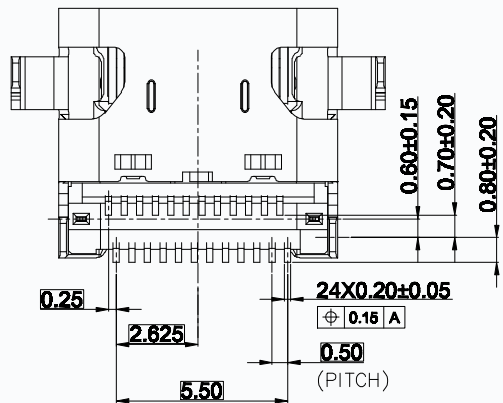
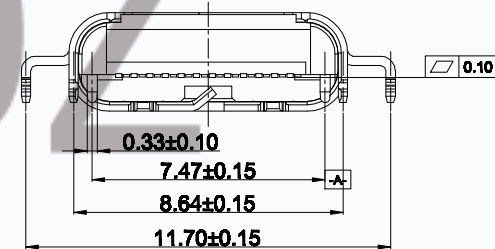
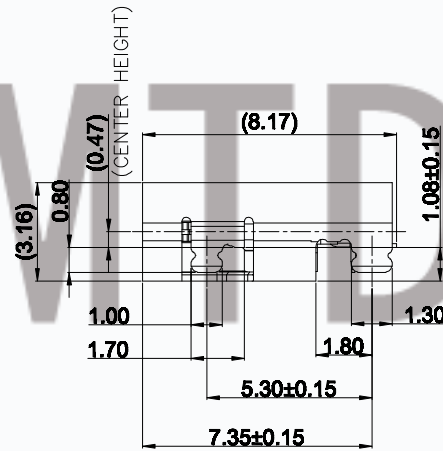
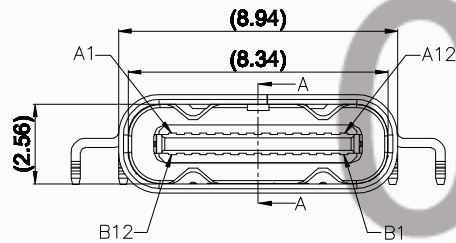

PART NO.
T11-24BS81 *

- H=镀金1u"
- J=镀金3u"
- K=镀金5u"
- M=镀金15u"
- N=镀金30u"

PIN ASSIGNMENT

A1	A2	A3	A4	A5	A6	A7	A8	A9	A10	A11	A12
GND	TX1+	TX1-	Vbus	CC1	D+	D-	SBU1	Vbus	RX2-	RX2+	GND
B12	B11	B10	B9	B8	B7	B6	B5	B4	B3	B2	B1
GND	RX1+	RX1-	Vbus	SBU2	D-	D+	CC2	Vbus	TX2-	TX2+	GND

CMTDDZ 东莞市田都科技有限公司
Dongguan TianDu Technology Co. Ltd.

TOLERANCE: X ±0.30 XX ±0.25 XXX ±0.20 XXX ±0.15 X*±1° XX*±0.5°	DESIGN BY :	DATE :	PART NAME: USB Type C 3.1 母座 无后盖 单壳 双贴SMT 沉板1.1mm,L=8.17mm
UNIT: mm [inch]	CHECKED BY:	DATE :	PART NO. T11-24BS81
SCALE:1:1 SIZE:A4	APPROVED BY:	DATE :	MOLD NO.
			DRAW NO.
			SHEET NO. 01 OF 02