

GP Component

REV.	ECN NO.	LOCATIONS	DESCRIPTION	DATE	DESIGN
A0			原始版本(INITIAL EDITION)	2020.12.15	ERIC

Date Code:
YY MM DD
DATE
MONTH
YEAR

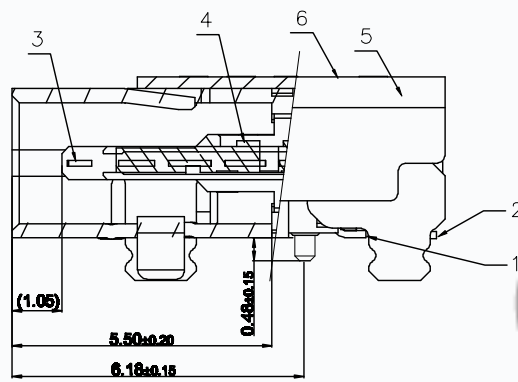
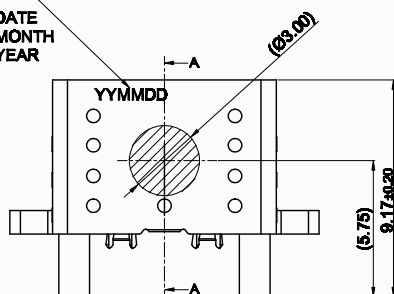

SECTION A-A(剖视图A-A)
SCALE 2:1 (比例 2:1)

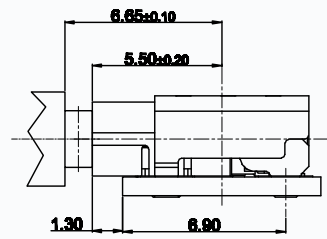
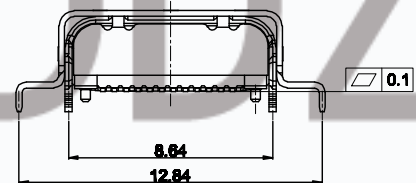
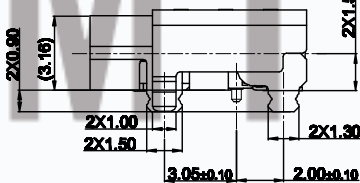
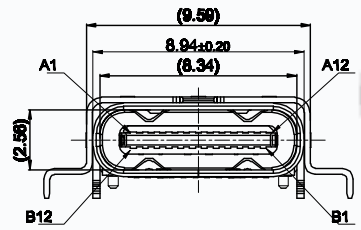

MATED CONDITION(REF.)

Pin定义:

A1	A2	A3	A4	A5	A6	A7	A8	A9	A10	A11	A12
GND	TX1+	TX1-	Vbus	CC1	D+	D-	SBU1	Vbus	RX2-	RX2+	GND
GND	RX1+	RX1-	Vbus	SBU2	D-	D+	CC2	Vbus	TX2-	TX2+	GND
B12	B11	B10	B9	B8	B7	B6	B5	B4	B3	B2	B1

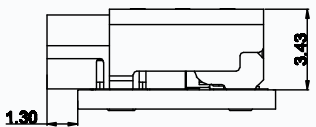
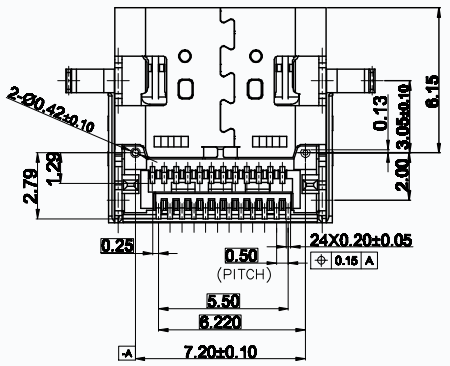

MOUNTING CONDITION(REF.)

ITEM	DESCRIPTION	QTY	MATERIAL	FINISH	REMARK
8	OUTSHELL	1	SUS304	NICKEL PLATING	0.20mm
6	INT SHELL	1	SUS304	NICKEL PLATING	0.20mm
4	MAIN HOUSING	1	PART HP 304208F, UL94 V-0, #85	-	COLOR:BLACK
3	MID PLATE	1	SUS304	-	0.10mm
2	BOTTOM TERMINAL	1	C1040	-	0.10mm
1	TOP TERMINAL	1	C1040	-	0.10mm

CMTDDZ 东莞市田都科技有限公司
Dongguan TianDu Technology Co. Ltd.

TOLERANCE: X XX ±0.30 XXX ±0.25 XXXX ±0.15 X° ±1° XX° ±0.5°	DESIGN BY :	DATE :	PART NAME: USB Type C 3.1 母座 双壳 双贴SMT 板上平贴, L=0.17mm
UNIT: mm [inch]	CHECKED BY:	DATE :	PART NO. T11-24B300
SCALE: 1:1	APPROVED BY:	DATE :	MOLD NO.
SIZE: A4			DRAW NO.
			SHEET NO. 01 OF 02