

版次	变更摘要	日期	序号	品名	材质
0	新产品发行	2019/07/20	①	XH2.5直针WTB胶芯	PA66 UL94V-0 米色 白色
			②	XH2.5直针WTB端子	铜合金/表面镀锡

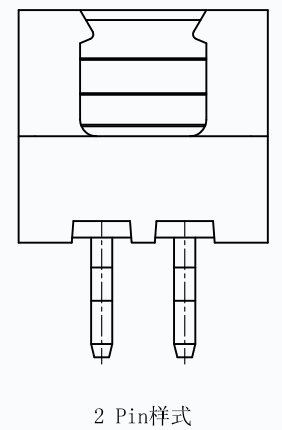
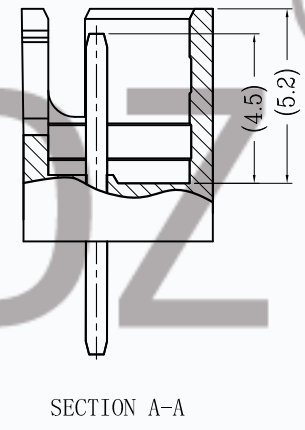
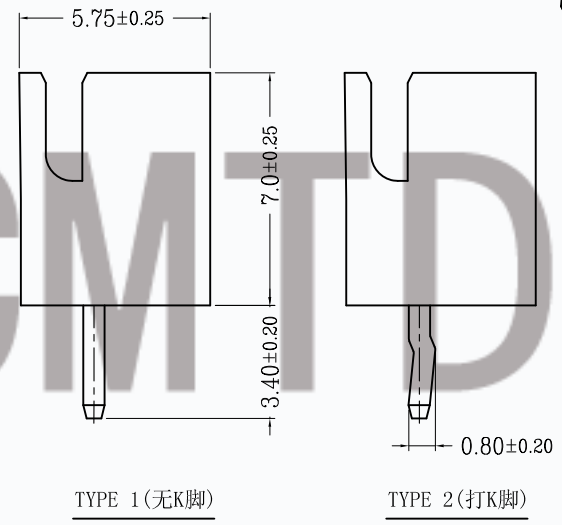
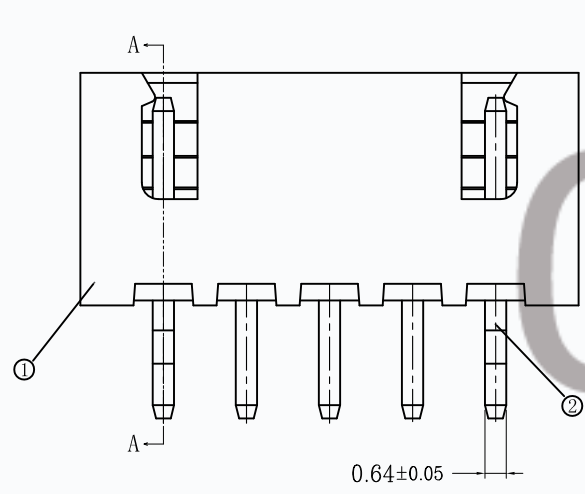
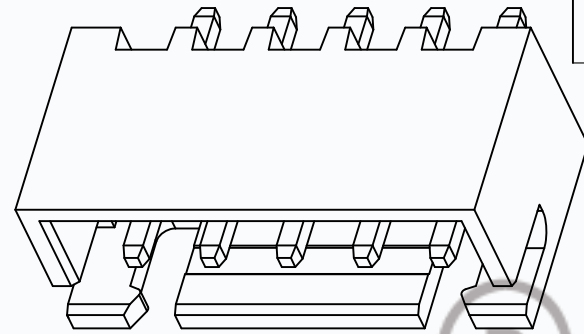
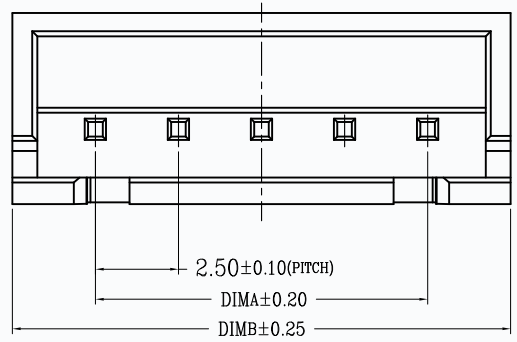

CKT	A	B	CKT	A	B
2	2.5	7.5	10	22.5	27.5
3	5.0	10.0	11	25.0	30.0
4	7.5	12.5	12	27.5	32.5
5	10.0	15.0	13	30.0	35.0
6	12.5	17.5	14	32.5	37.5
7	15.0	20.0	15	35.0	40.0
8	17.5	22.5	16	37.5	42.5
9	20.0	25.0			

技术指标 (Technical Index):

1. 温度范围 (Temperature range):  $-25^{\circ}\text{C} \sim +85^{\circ}\text{C}$ .
2. 额定电压 (Rated voltage): 250V, AC.
3. 额定电流 (Rated current): 3.0A AC, DC.
4. 接触电阻 (Contact resistance):  $\leq 20\text{m}\Omega$ .
5. 耐压值 (Withstanding voltage): 1000V AC/minute.
6. 绝缘电阻 (Insulation resistance):  $\geq 1000\text{M}\Omega$ .
7. 产品料号 (Product material No.):

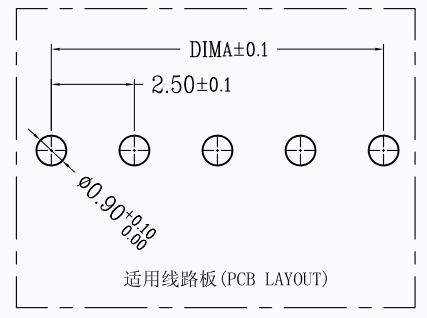

**T19-250ML--\*\* \* \*--\***

NO OF CKT (产品PIN数) ———— \* ———— \* ———— \*

Plating (电镀方式) ———— \* ———— \*

4: 端子全亮锡 (Terminal all bright tin)

Packing (包装方式) ———— \* ———— \*

P: PE袋装/盒装

DP	DIP型无K脚, 高温料无LOGO
D9	DIP型无K脚, 低温料无LOGO
DK	DIP型打K脚, 高温料无LOGO
K9	DIP型打K脚, 低温料无LOGO

RoHS

一般公差 (TOLERANCE)

X ±.50 XX ±.10

X ±.20 XXX ±.05

ANGLES ±1°

**CMTDDZ 东莞市田都科技有限公司**  
DONGGUAN TIANDU TECHNOLOGY CO., LTD

品名 (TITLE) XH2.5直针WTB 制图 (DR) Anlan

料号 (DWG.NO) T19-250ML--\*\*\*\*--\*\* 校对 (CHKD)

比例 (SCALE) 1:1 单位 (UNITS) mm 审核 (APPD)

张数 (SHEET) 1 OF 1 SIZE A4 REV A