

CMTDDZ 东莞市田都科技有限公司

Dongguan TianDu Technology Co. Ltd.

TYPE-C 3PIN-板上全贴SMT

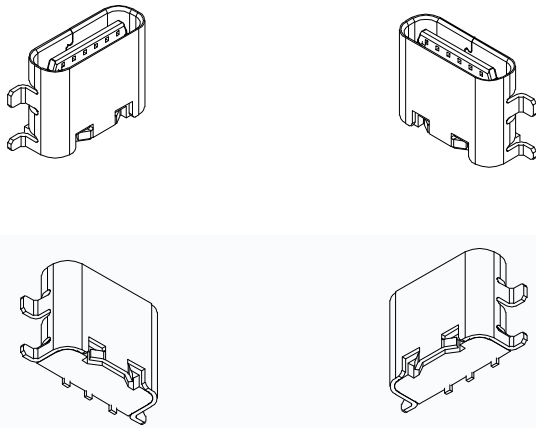

PART SPECIFICATIONS:

- MATERIAL SPECIFICATION:
 - HOUSING: HIGH TEMPERATURE RESISTANT PLASTIC, UL94 V-0.
 - CONTACTS: COPPER ALLOY
 - SHELL: STAINLESS STEEL
- PLATING SPECIFICATION:
 - CONTACTS:
 - Ni 50u" MIN. UNDER PLATED OVER ALL.
 - Au PLATED ON THE FUNCTIONAL AREA OF CONTACT.
 - Au PLATED ON SOLDER AREA.
 - FRONT SHELL:
 - Ni 50u" MIN. UNDER PLATED OVER ALL.
- MECHANICAL PERFORMANCE:
 - INSERTION FORCE: 0.5~2.0kgf.
 - REMOVAL FORCE: 0.6kgf~2.0kgf.
 - DURABILITY: 5000 CYCLES.
- ELECTRICAL PERFORMANCE:
 - CURRENT RATING: 3.0A
VOLTAGE RATING: 5.0V
 - LLCR:
 - VBUS & GND PINS AND OTHER PINS: 40mΩ/PIN MAX.
 - LLCR MAX. CHANGE OF ALL PINS: 10mΩ.
 - INSULATION RESISTANCE: 100MΩ MIN
 - DIELECTRIC WITHSTAND VOLTAGE, AC 100V FOR 1 MINUTE.
- ENVIRONMENTAL PERFORMANCE:
 - OPERATING TEMPERATURE: -25°C~+85°C.
- IR REFLOW:
 - THE PEAK TEMPERATURE ON THE BOARD SHALL BE MAINTAINED FOR 10 SECONDS AT 260°C.

尺寸参数 / PRODUCT DIMENSION

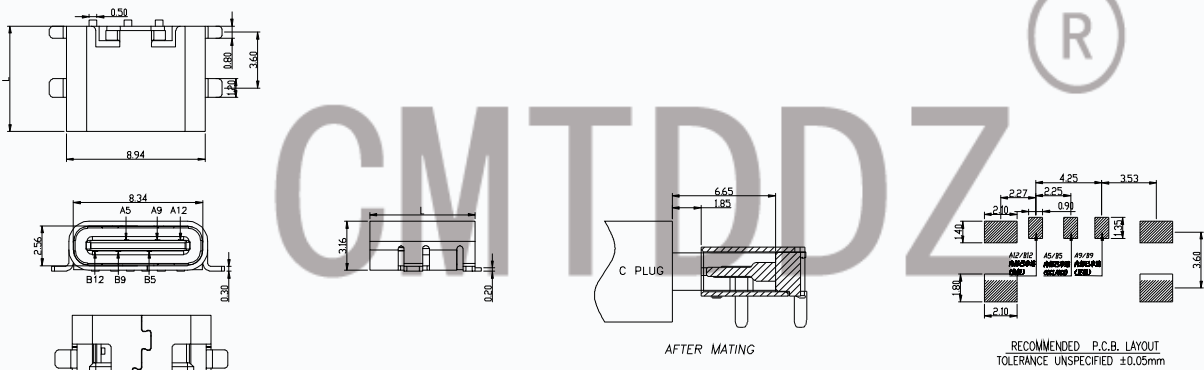

PIN ASSIGNMENTS			
A5	CC1	B12	GND
A9	VBUS	B9	VBUS
A12	GND	B5	CC2
L	L = 6.8	PIN	SIGNAL NAME
L	L = 6.5	PIN	SIGNAL NAME

TOLERANCE	NAME (INTENDED USE) CUSTOMER DRAWING	CMTDDZ 东莞市田都科技有限公司 Dongguan TianDu Technology Co. Ltd.		
X.X ±0.30 X.' ±10'	PART NO.	TITLE: TYPE-C 3PIN-板上全贴SMT		
.XX ±0.20 X.' ±8'	DESIGN: ERIC	DRAWG NO.		
.XXX ±0.10 .XX' ±5'	CHED:	SCALE SHEET REV.		
UNITS mm	APPD:	1:1 1/2 V0		
MATERILA				
FINISH				

包装规范 / PACKING SPECIFICATION

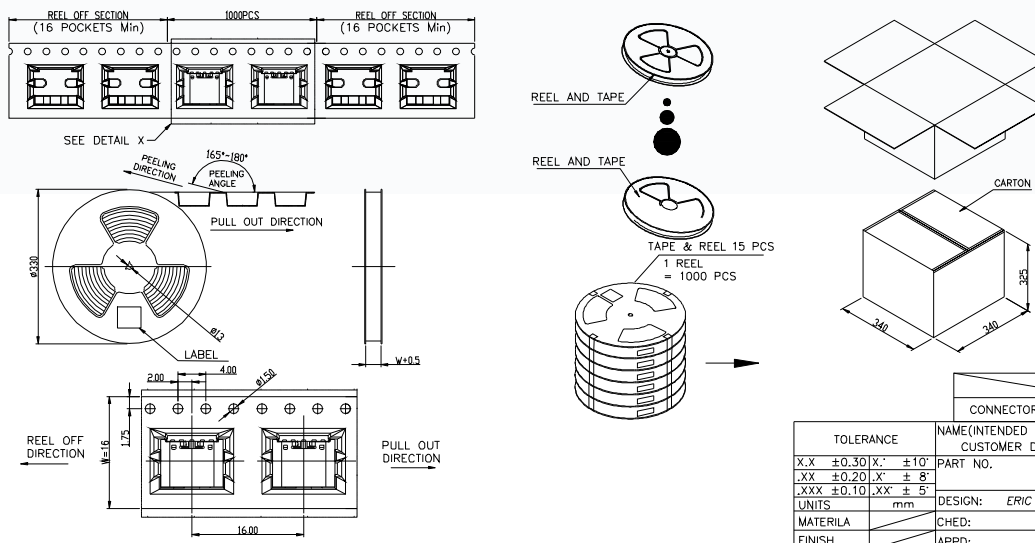

		REEL	CARTON
CONNECTOR (PCS)		1000	10000
TOLERANCE	NAME (INTENDED USE) CUSTOMER DRAWING	CMTDDZ 东莞市田都科技有限公司 Dongguan TianDu Technology Co. Ltd.	
X.X ±0.30 X.' ±10'	PART NO.	TITLE: TYPE-C 3PIN-板上全贴SMT	
.XX ±0.20 X.' ±8'	DESIGN: ERIC	DRAWG NO.	
.XXX ±0.10 .XX' ±5'	CHED:	SCALE SHEET REV.	
UNITS mm	APPD:	1:1 2/2 V0	
MATERILA			
FINISH			