

RoHS Compliant

REV	LTR	DESCRIPTION	DATE	REVISER	APPD
A		更新图面	2019-08-26	ERIC	

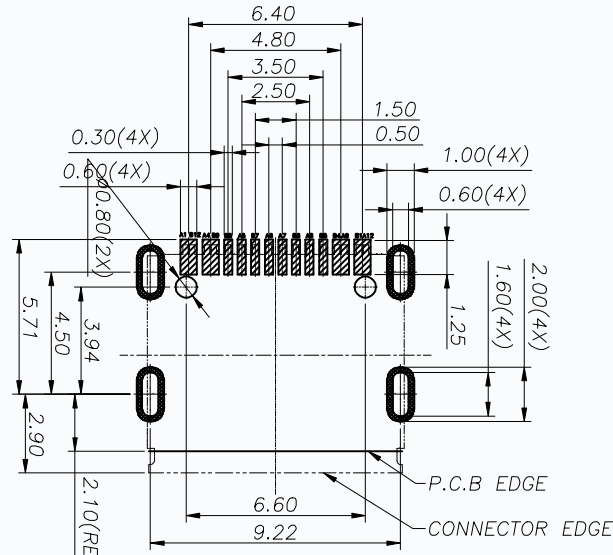

RECOMMENDED P.C.B. LAYOUT (T:0.80mm)  
TOLERANCE UNSPECIFIED ±0.05mm

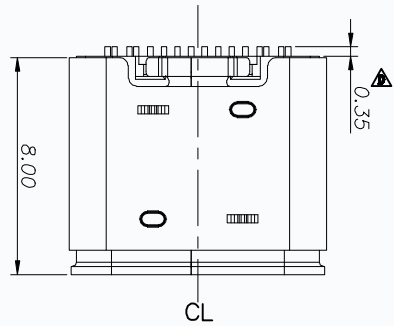
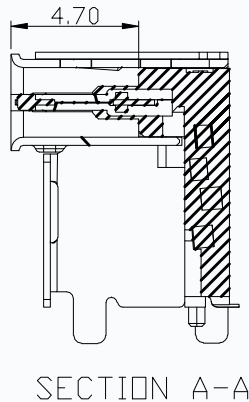
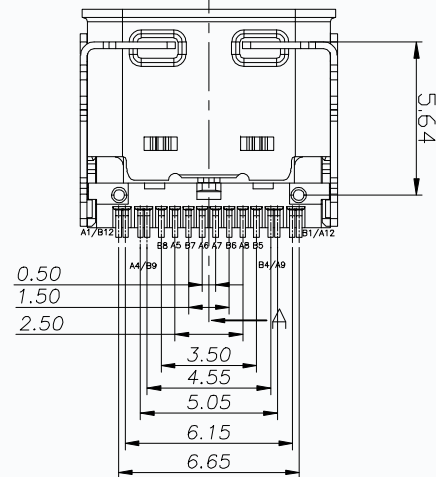
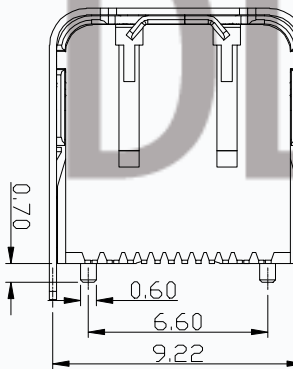
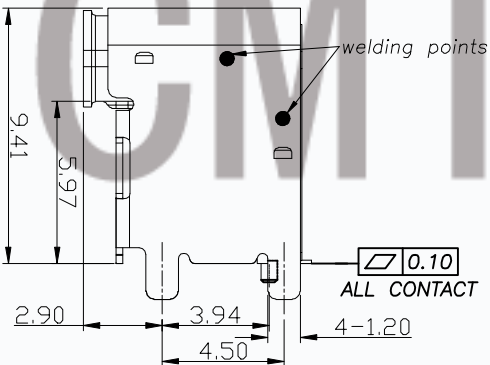
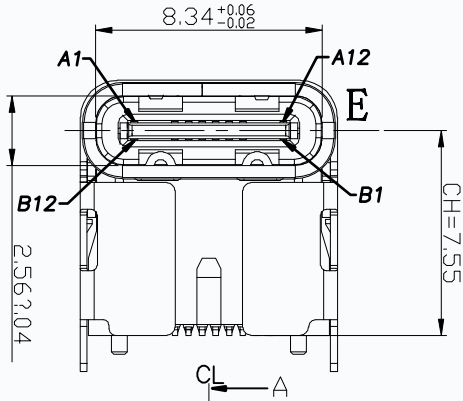

PIN ASSIGNMENTS

A1	GND	B12	GND
A2		B11	
A3		B10	
A4	VBUS	B9	VBUS
A5	CC1	B8	SBU2
A6	DP1	B7	DN2
A7	DN1	B6	DP2
A8	SBU1	B5	CC2
A9	VBUS	B4	VBUS
A10		B3	
A11		B2	
A12	GND	B1	GND
PIN	SIGNAL NAME	PIN	SIGNAL NAME

NOTE:

- MATERIAL SPECIFICATION:
  - HOUSING: HIGH TEMPERATURE RESISTANT PLASTIC, UL94 V-0.
  - CONTACTS: COPPER ALLOY
  - MID PLATE: STAINLESS STEEL
  - FRONT SHELL: STAINLESS STEEL
  - TOP SHELL: STAINLESS STEEL
- PLATING SPECIFICATION:
  - CONTACTS:
    - Ni 50u" MIN. UNDER PLATED OVER ALL.
    - Au 3u" PLATED ON THE FUNCTIONAL AREA OF CONTACT.
    - Au G/F PLATED ON SOLDER AREA.
  - FRONT SHELL & TOP SHELL:
    - Ni 30u" MIN. UNDER PLATED OVER ALL.
- MECHANICAL PERFORMANCE,
  - INSERTION FORCE: 0.5~2.0kgf.
  - REMOVAL FORCE: 0.8kgf~2.0kgf.
  - DURABILITY: 10000 CYCLES.
- ELECTRICAL PERFORMANCE,
  - CURRENT RATING: 5.0A  
VOLTAGE RATING: 5.0V
  - LLCR:
    - VBUS & GND PINS AND OTHER PINS: 40mA/PIN MAX.
    - SHIELD: 50mA/MAX.
    - LLCR MAX. CHANGE OF ALL PINS: 10mA
  - INSULATION RESISTANCE: 100MΩ MIN
  - DIELECTRIC WITHSTAND VOLTAGE, AC 100V FOR 1 MINUTE.
- ENVIRONMENTAL PERFORMANCE:
  - OPERATING TEMPERATURE: -25?~+85?.
  - THE PEAK TEMPERATURE ON THE BOARD SHALL
- IR REFLOW:
  - BE MAINTAINED FOR 10 SECONDS AT 260°C.

**CMTDDZ** 东莞市田都科技有限公司  
DONGGUAN TIANDU TECHNOLOGY CO., LTD.

<b>TOLERANCE</b>		<b>TITLE:</b> USB TYPE-C 16PIN SMT LCP黑色端子镀金 不锈钢壳镀镍 (CH:7.55)			
.000	±0.15	<b>PART NO.:</b> T11-16BS04-CH7.55		<b>DRAWING NO.:</b> CMTDDZ-TD98010003	
.00	±0.25	<b>SHEET:</b>	<b>SCALE:</b> 1 : 1	<b>UNIT:</b> mm	<b>SIZE:</b> A4
.0	±0.35	<b>ANGLE</b>	±2.0°	<b>REV.</b>	E
<b>APPD.</b>			<b>CHECK</b>	<b>DRAWN</b> ERIC	