

DRWG NO. :

MODEL NO.	KNOB(G/VG)
T4-244503S-G	(2~15)mm

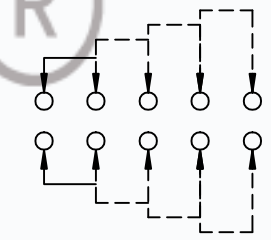

SCHMATIC(NON-SHORTING)

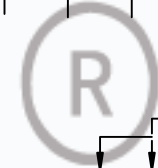
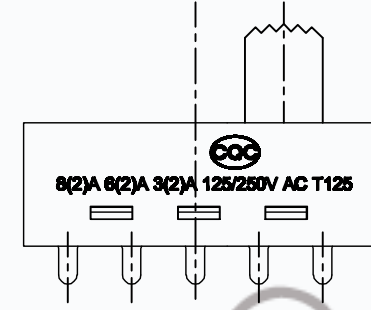
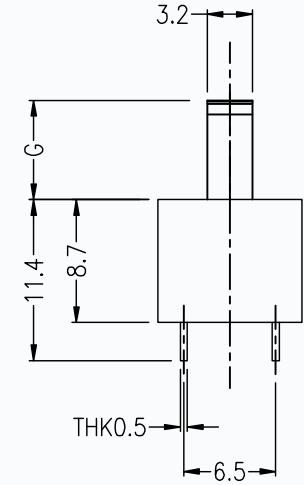
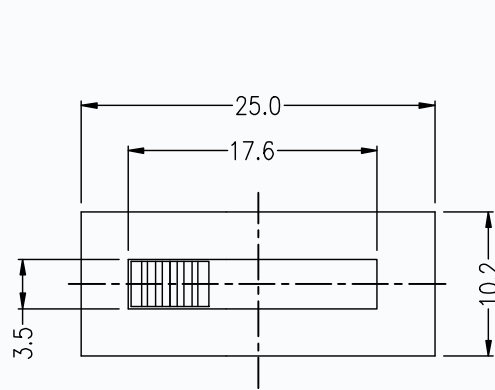
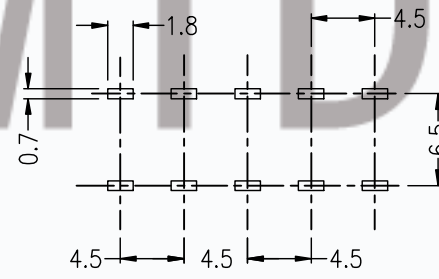
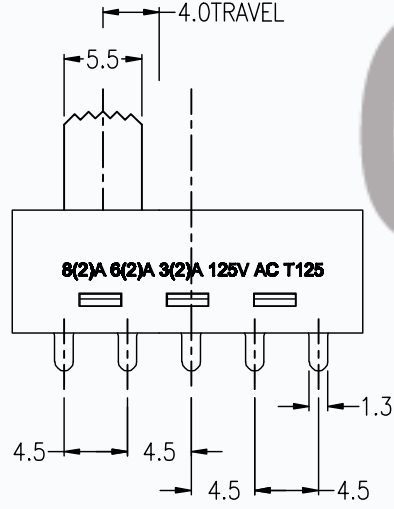

P.C.BOARD LAYOUT
BOTTOM VIEW

Specifications:

Rating	UL cUL: 6(2)A 3(2)A 125VAC TUV: 6(2)A 3(2)A 250V/125VAC CQC: 6(2)A 3(2)A 250V/125VAC
Contact Resistance	100mΩ MAX
Insulation Resistance	100MΩ MIN
Dielectric Voltage	AC 1500V 1 Minute
Operating Force (gf)	600+/-200 gf
Life test without load	10000 Cycles
Ambient Temperature Used	-25° C To 125° C

NO.	PARTS	MATERIALS	Q'TY	FINISHING
8	SPRING COIL	STEEL WIRE	1	NATURAL
7	STEEL BALL	STEEL	1	NATURAL
6	SPRING COIL	STEEL WIRE	4	NATURAL
5	CONTACT BRIDGE	COPPER ALLOY	2	Ag PLATED
4	TERMINAL	COPPER ALLOY	10	Ag PLATED
3	BOARD	HTPA	1	WHITE
2	PLASTIC COVER	HTPA	1	WHITE
1	KNOB	HTPA	1	WHITE

TOLERANCE UNLESS SPECIFIED		A	2021-05-20	初版
WITHIN 1.5mm : ±0.1mm	ISSUE	DATE	DESCRIPTIONS OF REVISION	
OVER 1.5mm : ±0.2mm	PROJECT AGL:		CAD FILE: T4-244503S-G	
TITLE : AC VERTICAL SLIDE SWITCH		UNIT : mm		
MODEL: T4-244503S-G		SCALE: 3 : 1	DWN.	ERIC
CMTDDZ 东莞市田都科技有限公司 DONGGUAN TIANDU TECHNOLOGY CO.,LTD.			CHK'D	MAIKO
			APPD.	Coco
				2021-05-20
				2021-05-20