

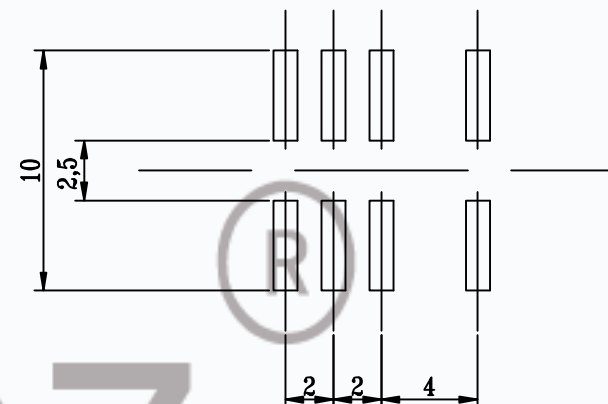

CAD FILE:T3-232005A-G



MODEL NO.	KNOB(G/VG)
T3-232005A-G	(2~15)mm



P.C.B. LAYOUT

SPECIFICATIONS	
Rating	0.5A 50V DC
CIRCUIT	2P3T
Timing	SHORTING
Travel	2.0mm
Contact Resistance	< 100 mΩ
Operating Force	350gf ± 100gf
Operating Life	10.000 cycles

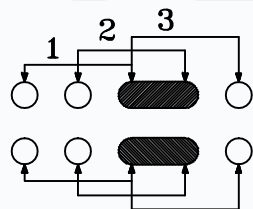
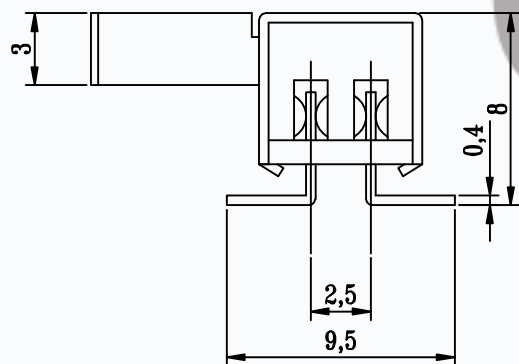
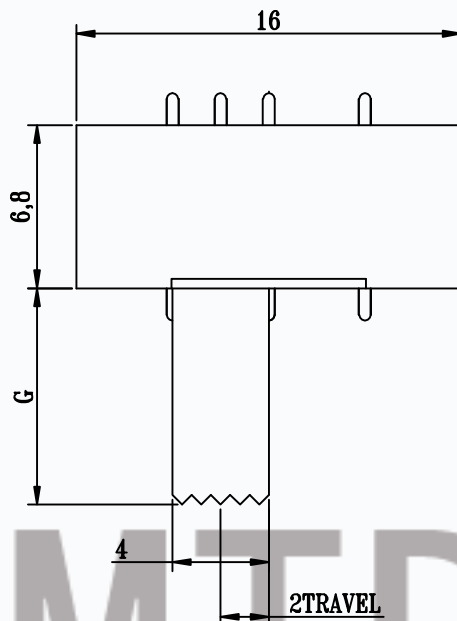
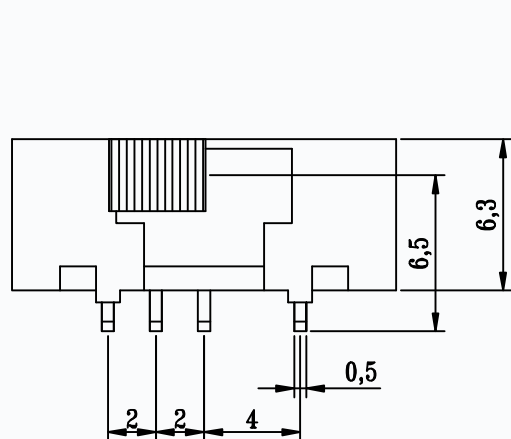

SCHEMATIC (SHORTING)

NO.	PARTS	MATERIALS	Q'TY	FINISH	TOLERANCE	DESCRIPTIONS OF REVISION	APPD.	
8					TOLERANCE UNLESS SPECIFIED WITHIN 1.5mm : ±0.1mm OVER 1.5mm : ±0.2mm	THESE DRAWINGS AND SPECIFICATIONS ARE THE PROPERTY OF DONGGUAN TIANDU TECHNOLOGY CO.,LTD. AND SHALL NOT BE REPRODUCED, COPIED OR USED IN ANY MANNER WITHOUT THE PRIOR WRITTEN CONSENT OF DONGGUAN TIANDU TECHNOLOGY CO., LTD		
7	STEEL BALL	STEEL	1	NATURAL				
6	SPRING	STEEL WIRE	1	NATURAL				
5	CONTACT CLIP	PBS STRIP	2	Ag PLATED				
4	TERMINAL	BRASS STRIP	8	Ag PLATED				
3	BASE	PHENOLIC RESIN	1	NATURAL	TITLE : HORIZONTAL SLIDE SWITCH	UNIT : mm	DRWG NO.: CMTDDZ-T3-232005A-G	
2	KNOB	PA9T	1	BLACK	MODEL: T3-232005A-G	SCALE: 5:1	DWN. ERIC 2013-6-17	
1	FRAME	STEEL STRIP	1	Ni PLATEFD 24H	<b>CMTDDZ</b> 东莞市田都科技有限公司 DONGGUAN TIANDU TECHNOLOGY CO.,LTD.	CHK'D	MAIKO 2013-6-17	
						APPD.	Coco 2013-6-17	