

产品规格 Specifications:

Rating	UL cUL: 6(2)A 3(2)A 125VAC TUV: 6(2)A 3(2)A 250V/125VAC CQC: 6(2)A 3(2)A 250V/125VAC
Contact Resistance	100mΩ MAX
Insulation Resistance	100MΩ MIN
Dielectric Voltage	AC 1500V 1 Minute
Operating Force (gf)	500+/-200 gf
Life test without load	10000 Cycles
Ambient Temperature Used	-25° C To 125° C

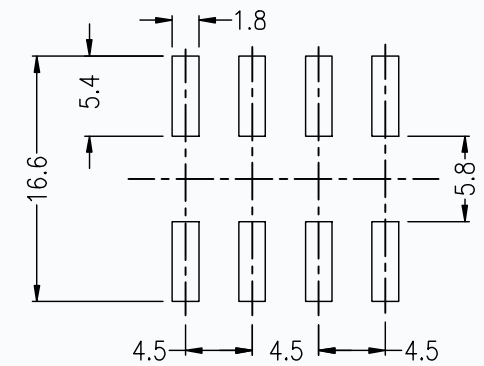
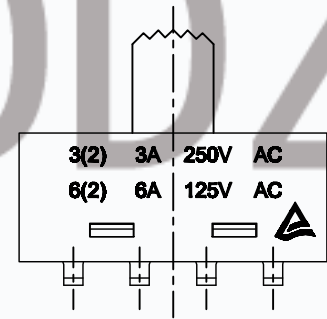
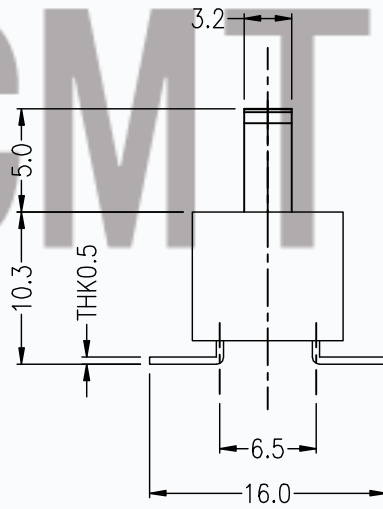
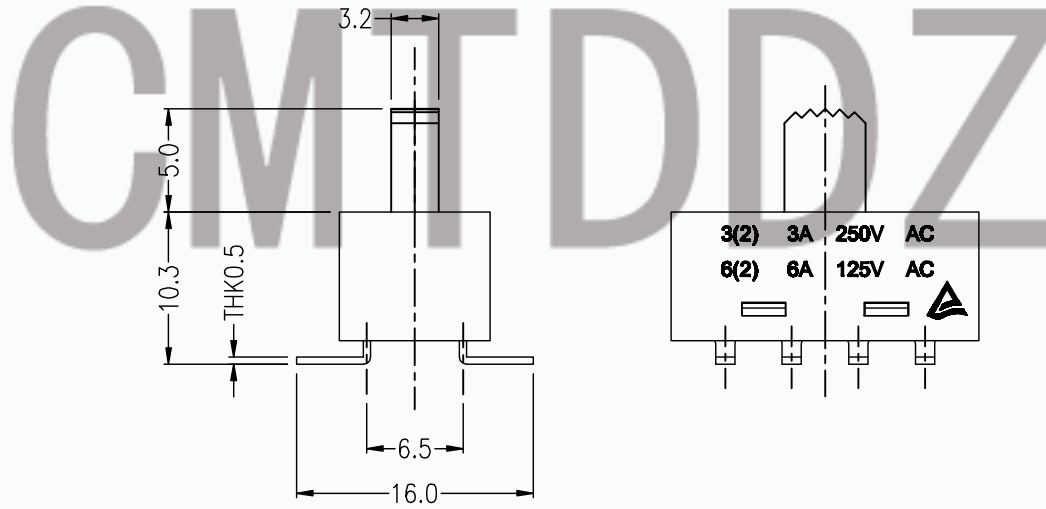
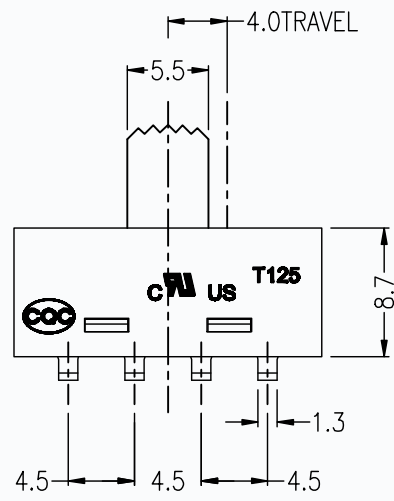
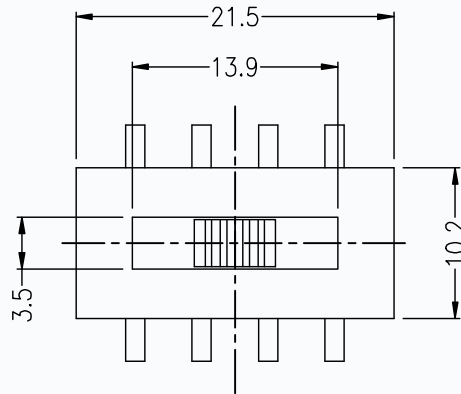
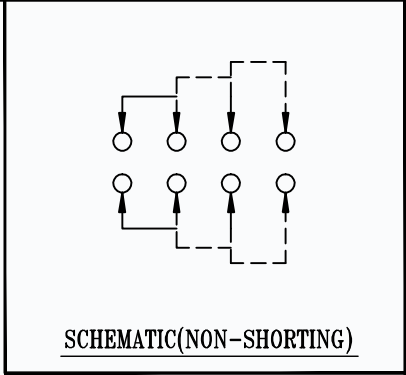

P.C.BOARD LAYOUT
BOTTOM VIEW

8	SPRING COIL	STEEL WIRE	1	NATURAL	TOLERANCE UNLESS SPECIFIED	A	2021-July-20	初版	APPD.
7	STEEL BALL	STEEL	1	NATURAL					
6	SPRING COIL	STEEL WIRE	4	NATURAL	WITHIN 1.5mm : ±0.1mm	ISSUE	DATE	DESCRIPTIONS OF REVISION	APPD.
5	CONTACT BRIDGE	COPPER ALLOY	2	Ag PLATED	OVER 1.5mm : ±0.2mm	PROJECT	AGL:		
4	TERMINAL	COPPER ALLOY	8	Ag PLATED	TITLE : AC VERTICAL SLIDE SWITCH		UNIT : mm	P/N: 1010156000103040	
3	BOARD	LCP	1	BLACK	MODEL: T4-234523S-G5		SCALE: 3 : 1	DWN.	
2	PLASTIC COVER	LCP	1	BLACK	东莞市田都科技有限公司 DONG GUAN TIANDU TECHNOLOGY CO., LTD		CHK'D		
1	KNOB	LCP	1	BLACK			APPD.		
NO.	PARTS	MATERIALS	Q'TY	FINISHING					