

产品规格 Specifications:

Rating	3A 250VAC/6A 125VAC
Contact Resistance	100mΩ MAX
Insulation Resistance	500MΩ MIN
Dielectric Voltage	AC 1500V 1 Minute
Operating Force (gf)	600+/-200 gf
Life test without load	10,000 Cycles
Ambient Temperature Used	-25° C To 105° C

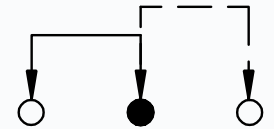

SCHEMATIC (NON-SHORTING)

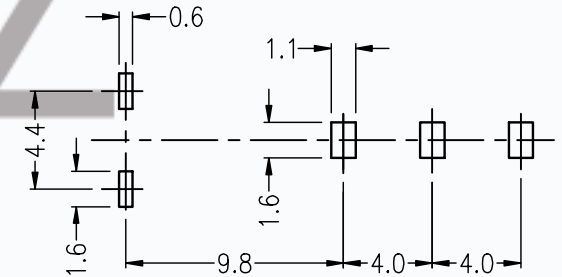
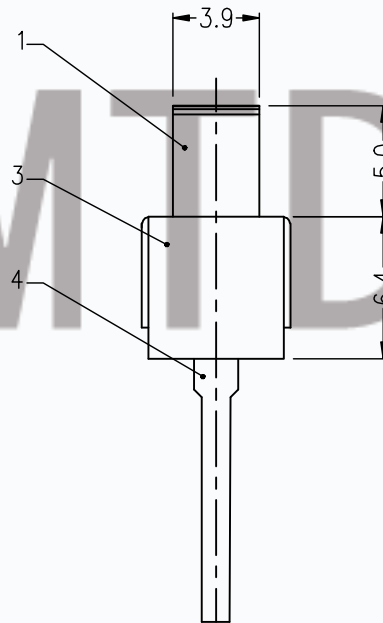
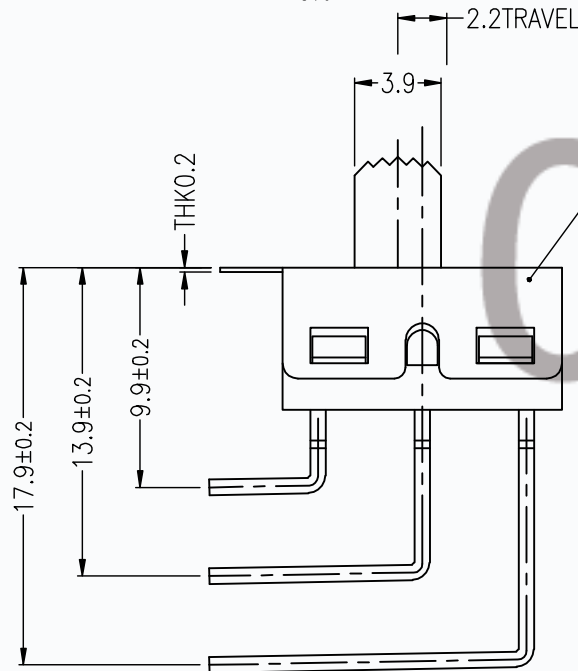

P.C.B LAYOUT  
BOTTOM VIEW

NO.	PARTS	MATERIALS	Q'TY	FINISHING	TOLERANCE UNLESS SPECIFIED	A/0	2021-Apr-15	初版	ISSUE	DATE	DESCRIPTIONS OF REVISION	APPD.
6	STEEL BALL	STEEL	1	NATURAL	WITHIN 5.0mm : ±0.1mm							
6	SPRING COIL	STEEL WIRE	1	NATURAL	OVER 5.0mm : ±0.2mm							
5	CONTACT CLIP	COPPER ALLOY	1	Ag PLATED								
4	TERMINAL	COPPER ALLOY	3	Ag PLATED								
3	HOUSING	NYLON PA	1	RED								
2	METAL COVER	STAINLESS STEEL	1	NATURAL								
1	KNOB	NYLON PA	1	BLACK								
					PROJECT AGL:		CAD FILE: T4-124706-G					
					TITLE : AC VERTICAL SLIDE SWITCH		UNIT : mm		P/N: 1010151050123020			
					MODEL: T4-124706-G5		SCALE: 3 : 1		DWN.			
					东莞市田都科技有限公司 DONG GUAN SHI TIANDU TECHNOLOGY CO., LTD				CHK'D			
									APPD.			