

CAD FILE:

DIMENSIONS

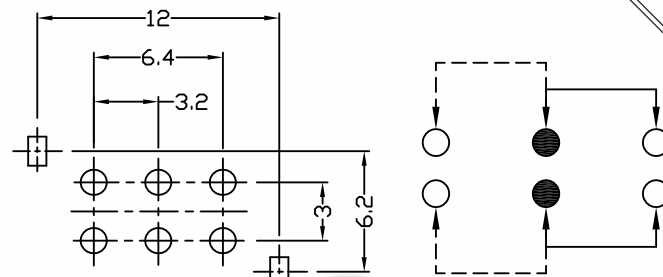
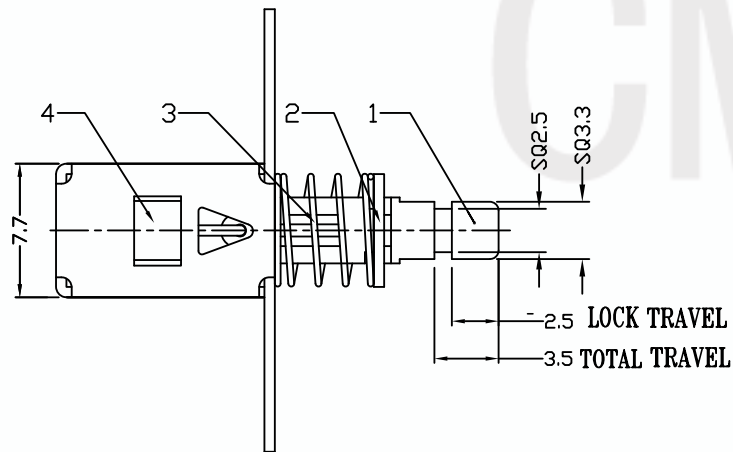
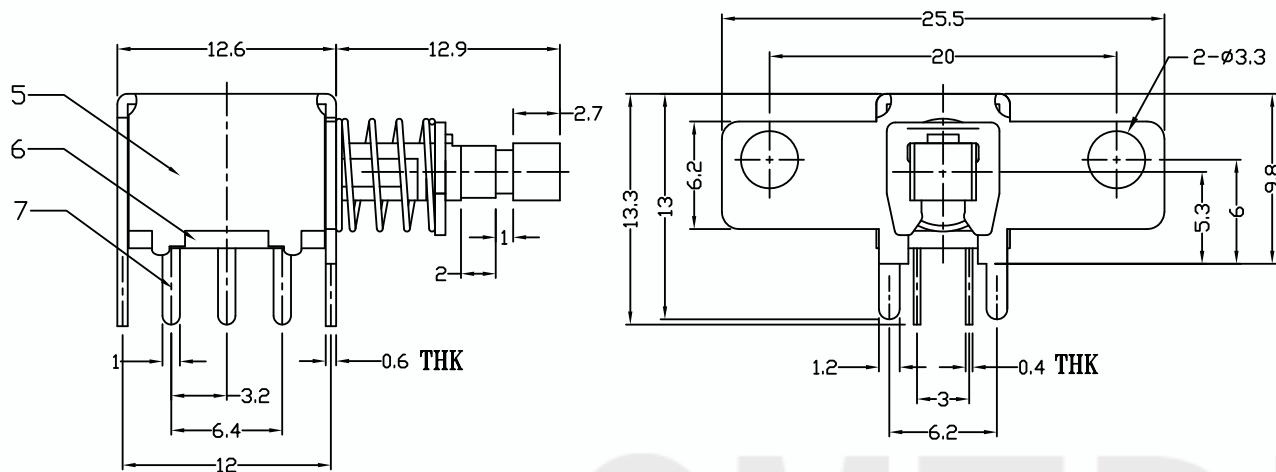

P.C.B LAYOUT CIRCUIT DIAGRAM

ELECTRO-MECHANICAL CHARACTERISTICS

Rating	0.3A 50V DC	
Circuit	2P2T	
Contact Resistance	< 100 mΩ MAX	
Timing	NON-SHORTING	
Operationg Mode	SELF-LOCK	T5-223006L
	NON-LOCK	T5-223006N
Stroke	FULL 3.5mm	LOCK 2.5mm
Operating Force	350gf ± 100gf	
Operating Life	10.000 cycles	



NO.	PARTS	MATERIALS	Q'TY	FINISHING
9	CONTACT CLIP	PBS STRIP	2	Ag PLATED
8	TERMINAL	BRASS STRIP	6	Ag PLATED
7	BASE	PHENOLIC RESIN	1	NATURAL
6	FRAME	STEEL STRIP	1	NI PLATED
5	SPRING PLATE	PBS STRIP	1	NATURAL
4	CAM STICK	PBS WIRE	1	NATURAL
3	SPRING	STEEL WIRE	1	NI PLATED
2	BLOCK	STEEL STRIP	1	NI PLATED
1	KNOB	PA66	1	BLACK

<p>TOLERANCE UNLESS SPECIFIED</p> <p>WITHIN 1.5mm : ±0.1mm OVER 1.5mm : ±0.2mm</p>	<p>THESE DRAWINGS AND SPECIFICATIONS ARE THE PROPERTY OF DONGGUAN TIANDU TECHNOLOGY CO., LTD. AND SHALL NOT BE REPRODUCED, COPIED OR USED IN ANY MANNER WITHOUT THE PRIOR WRITTEN CONSENT OF DONGGUAN TIANDU TECHNOLOGY CO., LTD</p>	DESCRIPTIONS OF REVISION		APPD.	
		TITLE : HORIZONTAL PUSH SWITCH		UNIT : mm	DRWG NO.: CMTDDZ-T5-223006NL-00
MODEL: T5-223006NL		SCALE: 3:1	DWN.	ERIC	2013-6-17
<p>CMTDDZ 东莞市田都科技有限公司 DONGGUAN TIANDU TECHNOLOGY CO., LTD.</p>		CHK'D	MAIKO	2013-6-17	
		APPD.	Coco	2013-6-17	