

CAD FILE:

| | |
|-------------|------------|
| MODEL NO. | KNOB(L/VG) |
| T4-244525-G | (2~15)mm |

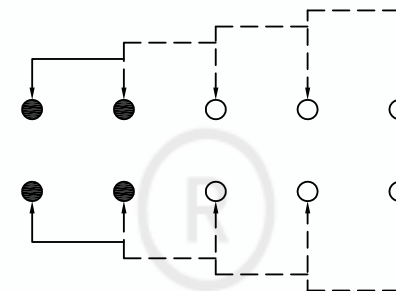

SCHEMATIC (NON-SHORTING)

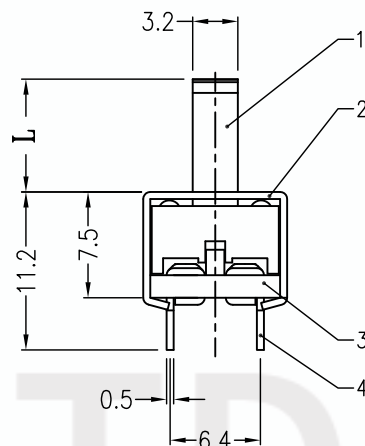
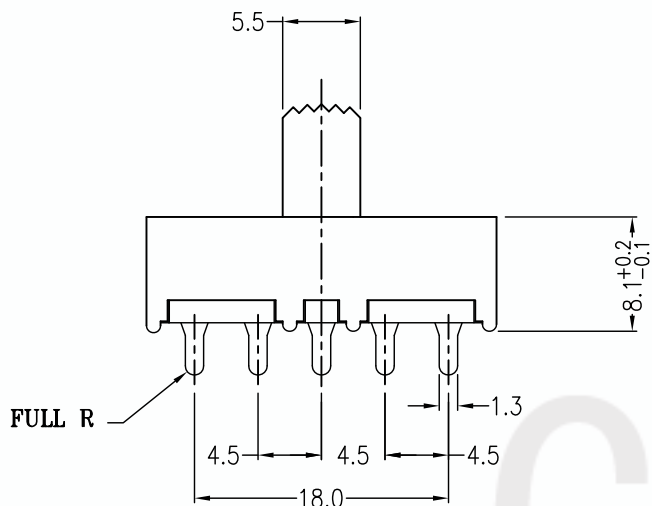
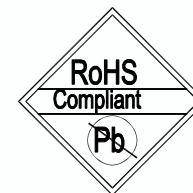
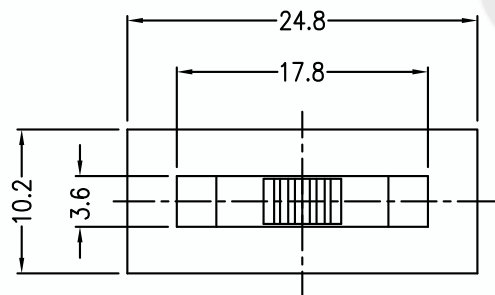

SPECIFICATIONS

| | |
|--------------------|---------------------|
| Rating | 3A 250VAC/6A 125VAC |
| CIRCUIT | 2P4T |
| TIMING | NON-SHORTING |
| Travel | 4.5mm |
| Contact Resistance | < 100 mΩ |
| Operating Force | 600gf ± 200gf |
| Operating Life | 10.000 cycles |

| NO. | PARTS | MATERIALS | Q'TY | FINISH | TOLERANCE UNLESS SPECIFIED WITHIN 1.5mm : ±0.1mm OVER 1.5mm : ±0.2mm | THESE DRAWINGS AND SPECIFICATIONS ARE THE PROPERTY OF DONGGUAN TIANDU TECHNOLOGY CO.,LTD. AND SHALL NOT BE REPRODUCED, COPIED OR USED IN ANY MANNER WITHOUT THE PRIOR WRITTEN CONSENT OF DONGGUAN TIANDU TECHNOLOGY CO., LTD | DESCRIPTIONS OF REVISION | APPD. |
|-----|--------------|----------------|------|-----------|---|--|-------------------------------|-----------------|
| 8 | | | | | | | | |
| 7 | STEEL BALL | STEEL | 1 | NATURAL | | | | |
| 6 | SPRING COIL | STEEL WIRE | 1 | NATURAL | | | | |
| 5 | CONTACT CLIP | PBS STRIP | 2 | Ag PLATED | | | | |
| 4 | TERMINAL | BRASS STRIP | 10 | Ag PLATED | TITLE : AC SLIDE SWITCH | UNIT : mm | DRWG NO.: CMTDDZ-T4-244525-00 | |
| 3 | BASE | PHENOLIC RESIN | 1 | NATURAL | MODEL: T4-244525-G | SCALE: 3:1 | DWN. | ERIC 2013-6-17 |
| 2 | KNOB | POM | 1 | BLACK | CMTDDZ 东莞市田都科技有限公司 DONGGUAN TIANDU TECHNOLOGY CO.,LTD. | | CHK'D | MAIKO 2013-6-17 |
| 1 | FRAME | STEEL STRIP | 1 | NI PLATED | | | APPD. | Coco 2013-6-17 |