

MODEL NO.	KNOB(L/G)
T2-424008-G	(2~15)mm

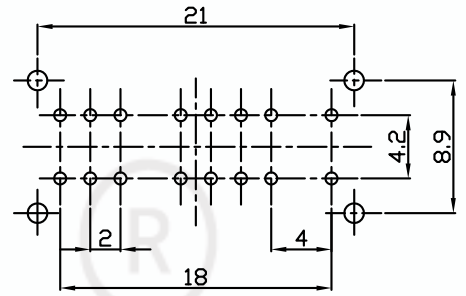

P.C.B LAYOUT  
BOTTOM VIEW

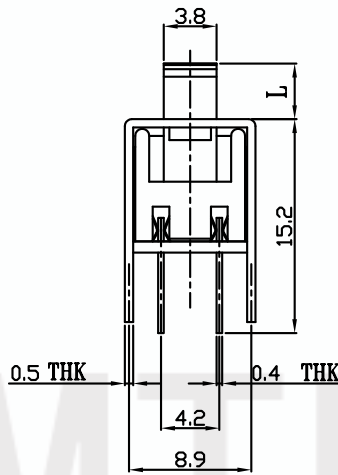
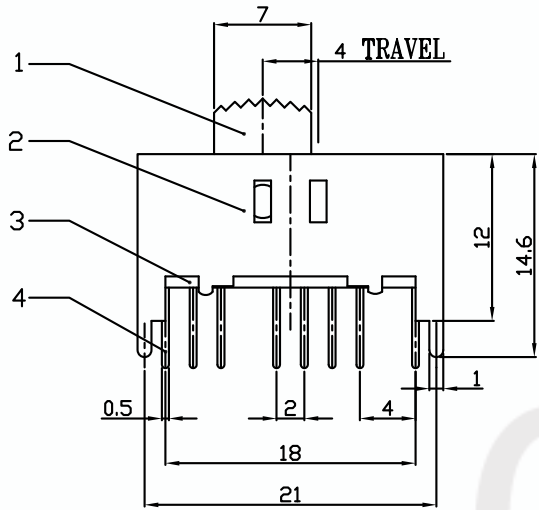
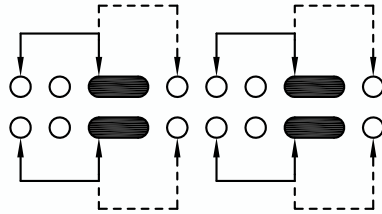
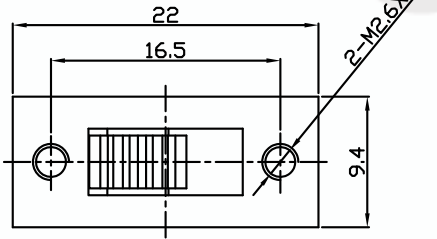

SCHEMATIC (SHORTING)

SPECIFICATIONS	
Rating	0.3A 50V DC
CIRCUIT	4P2T
Timing	SHORTING
Travel	4.0mm
Contact Resistance	< 100 mΩ
Operating Force	250gf ± 100gf
Operating Life	10.000 cycles

NO.	PARTS	MATERIALS	Q'TY	FINISH	TOLERANCE	DESCRIPTIONS OF REVISION	APPD.
8					UNLESS SPECIFIED	THESE DRAWINGS AND SPECIFICATIONS ARE THE PROPERTY OF DONGGUAN TIANDU TECHNOLOGY CO., LTD. AND SHALL NOT BE REPRODUCED, COPIED OR USED IN ANY MANNER WITHOUT THE PRIOR WRITTEN CONSENT OF DONGGUAN TIANDU TECHNOLOGY CO., LTD	
7	STEEL BALL	STEEL	2	NATURAL			
6	SPRING	STEEL STRIP	1	NATURAL	WITHIN 1.5mm : ±0.1mm		
5	CONTACT CLIP	BRASS STRIP	4	Ag PLATED	OVER 1.5mm : ±0.2mm		
4	TERMINAL	BRASS STRIP	16	Ag PLATED OVER Ni PLATED		TITLE : VERTICAL SLIDE SWITCH	UNIT : mm
3	BASE	PHENOLIC RESIN	1	NATURAL		DRWG NO.: CMTDDZ-T2-424008-00	
2	FRAME	STEEL STRIP	1	BLACK		MODEL: T2-424008-G	SCALE: 3:1
1	KNOB	POM	1	BLACK			DWN. ERIC 2013-6-17
							CHK'D MAIKO 2013-6-17
							APPD. Coco 2013-6-17

**CMTDDZ** 东莞市田都科技有限公司  
DONGGUAN TIANDU TECHNOLOGY CO.,LTD.