

CAD FILE:

MODEL NO.	KNOB(G/VG)
T2-232506-G	(2~15)mm

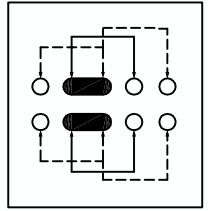
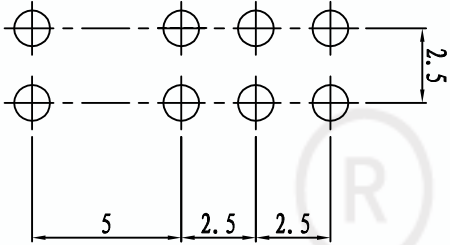
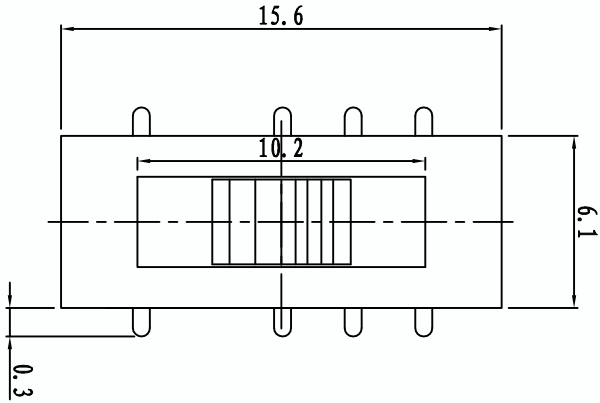

P. C. B LAYOUT

P.C.B LAYOUT
BOTTOM VIEW

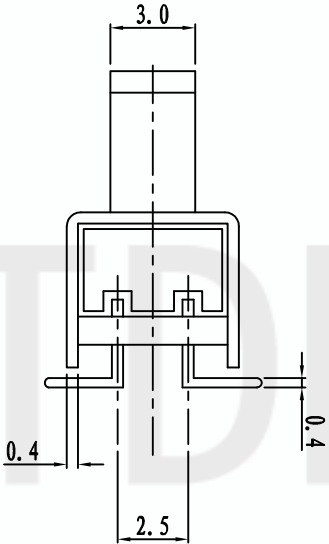
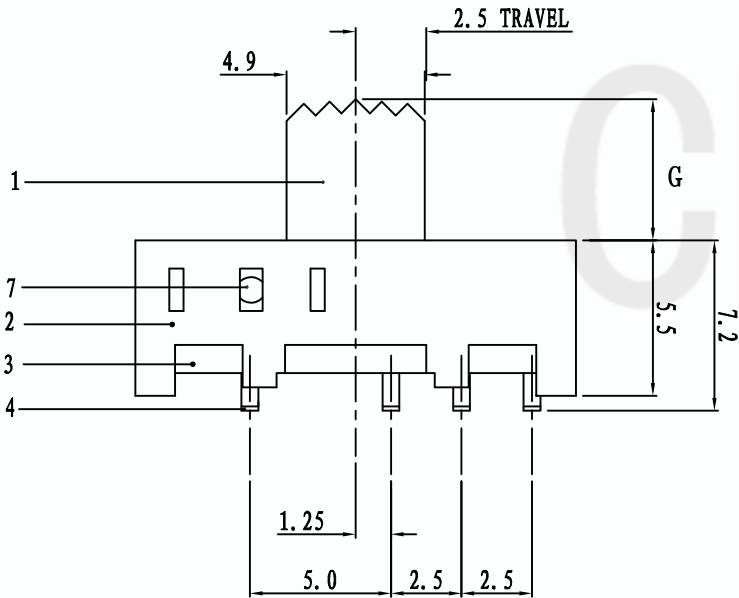

SPECIFICATIONS	
Rating	0.5A 50V DC
CIRCUIT	2P3T
Timing	SHORTING
Travel	2.5mm
Contact Resistance	< 100 mΩ
Operating Force	250gf ± 100gf
Operating Life	10,000 cycles

NO.	PARTS	MATERIALS	Q'TY	FINISH	TOLERANCE UNLESS SPECIFIED WITHIN 1.5mm : ±0.1mm OVER 1.5mm : ±0.2mm		THESE DRAWINGS AND SPECIFICATIONS ARE THE PROPERTY OF DONGGUAN TIANDU TECHNOLOGY CO.,LTD. AND SHALL NOT BE REPRODUCED, COPIED OR USED IN ANY MANNER WITHOUT THE PRIOR WRITTEN CONSENT OF DONGGUAN TIANDU TECHNOLOGY CO., LTD	DESCRIPTIONS OF REVISION			APPD.
8											
7	STEEL BALL	STEEL	2	NATURAL							
6	SPRING	STEEL WIRE	1	NATURAL							
5	CONTACT CLIP	PBS STRIP	2	Ag PLATED							
4	TERMINAL	BRASS STRIP	8	Ag PLATED	TITLE : VERTICAL SLIDE SWITCH		UNIT : mm	DRWG NO.: CMTDDZ-T2-232506-00			
3	BASE	PHENOLIC RESIN	1	NATURAL	MODEL: T2-232506-G(曲脚)		SCALE: 3:1	DWN.	ERIC	2013-6-17	
2	FRAME	STEEL STRIP	1	BLACK	CMTDDZ 东莞市田都科技有限公司 DONGGUAN TIANDU TECHNOLOGY CO.,LTD.			CHK'D	MAIKO	2013-6-17	
1	KNOB	POM	1	BLACK				APPD.	Coco	2013-6-17	