

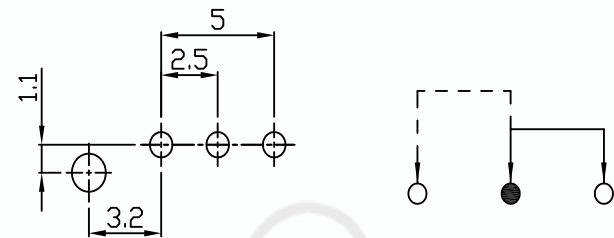

DIMENSIONS

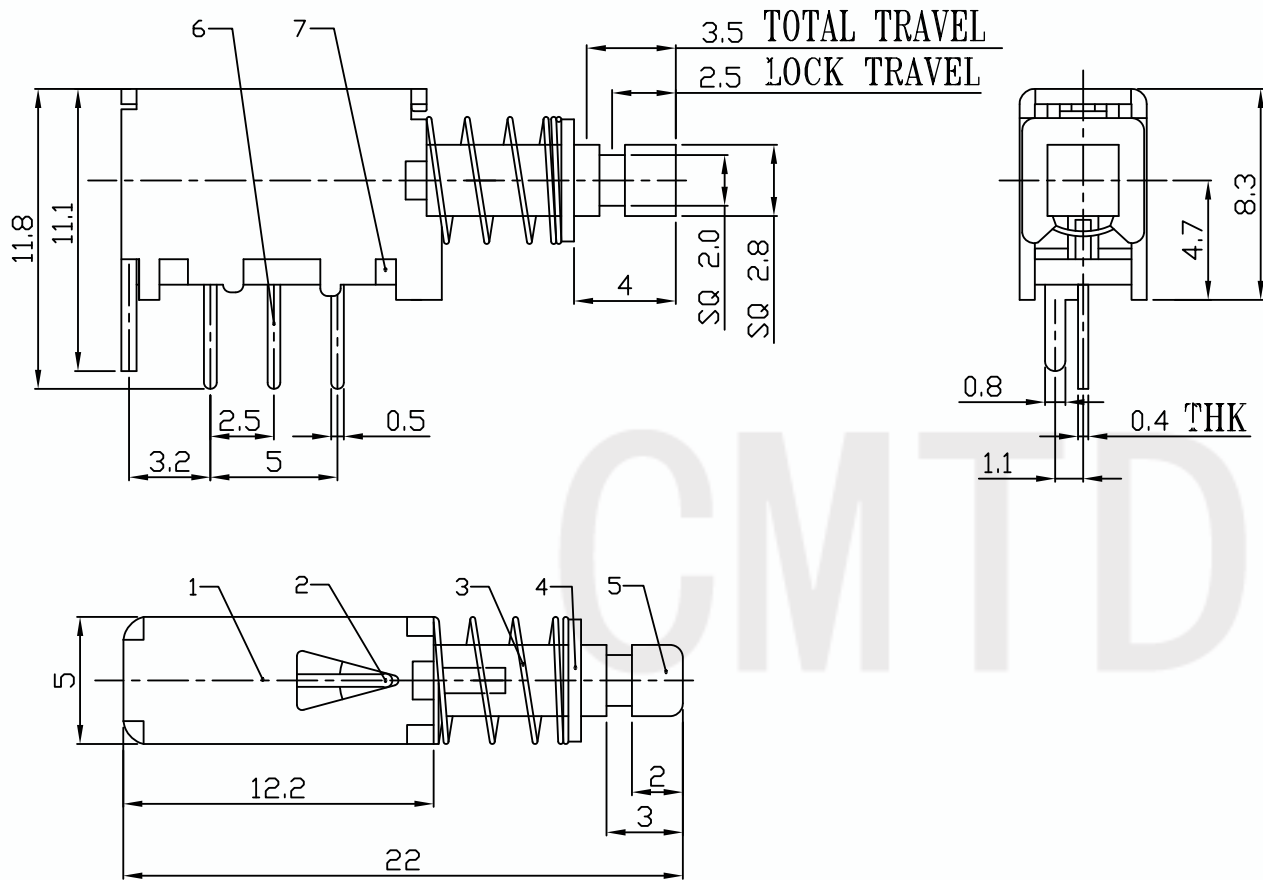

P.C.B LAYOUT CIRCUIT DIAGRAM

ELECTRO-MECHANICAL CHARACTERISTICS

Rating	0.3A 50V DC	
Circuit	1P2T	
Contact Resistance	< 30 mΩ MAX	
Timing	NON-SHORTING	
Operating Mode	SELF-LOCK	
Stroke	FULL 3.5mm	LOCK 2.5mm
Operating Force	250gf ± 100gf	
Operating Life	10.000 cycles	

NO.	PARTS	MATERIALS	Q'TY	FINISHING						
9	CONTACT CLIP	PBS C5210R-EH	1	Ag CLAD	TOLERANCE UNLESS SPECIFIED WITHIN 1.5mm : ±0.1mm OVER 1.5mm : ±0.2mm	THESE DRAWINGS AND SPECIFICATIONS ARE THE PROPERTY OF DONGGUAN TIANDU TECHNOLOGY CO., LTD. AND SHALL NOT BE REPRODUCED, COPIED OR USED IN ANY MANNER WITHOUT THE PRIOR WRITTEN CONSENT OF DONGGUAN TIANDU TECHNOLOGY CO., LTD	DESCRIPTIONS OF REVISION		APPD.	
8	SPRING PLATE	PBS STRIP	1	NATURAL						
7	BASE	PHENOLIC RESIN	1	NATURAL						
6	TERMINAL	BRASS STRIP	3	Ag PLATED OVER NI PLATED						
5	KNOB	POM	1	BLUE/BLACK						
4	BLOCK	STELL STRIP	1	NI PLATED	TITLE : HORIZONTAL PUSH SWITCH	UNIT : mm	DRWG NO.: CMTDDZ-T5-122506L-00			
3	SPRING	STEEL WIRE	1	NI PLATED	MODEL: T5-122506L	SCALE: 4:1	DWN.	ERIC	2013-6-17	
2	CAM STICK	PBS WIRE	1	NATURAL	CMTDDZ 东莞市田都科技有限公司 DONGGUAN TIANDU TECHNOLOGY CO., LTD.	CHK'D	MAIKO	2013-6-17		
1	FRAME	STEEL STRIP	1	NI PLATED		APPD.	Coco	2013-6-17		