

CAD FILE:

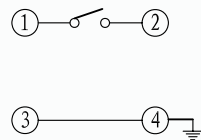

CIRCUIT DIAGRAM

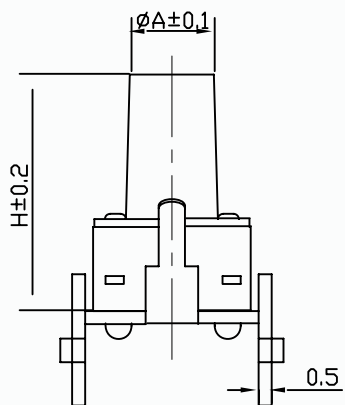
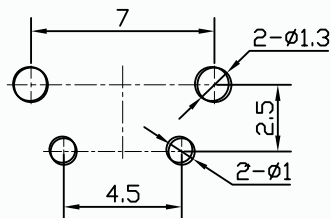

P.C.B LAND PATTERN

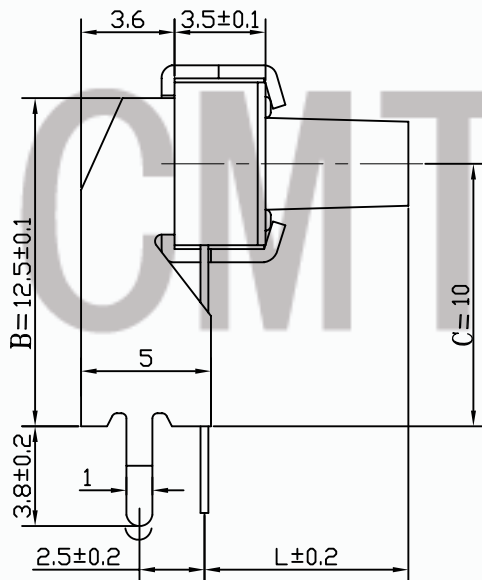
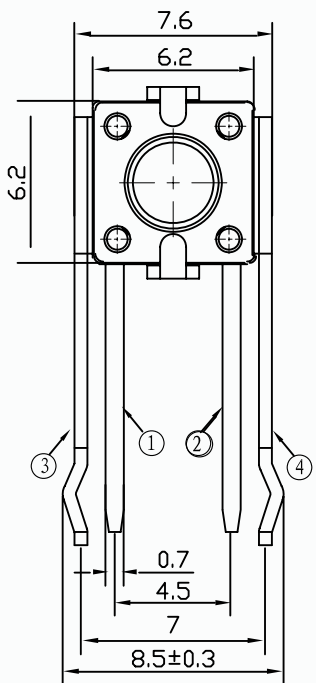

MODEL NO.	T6-6060BM-XX-H-B-C				
XX	H(mm)	L(mm)	A(mm)	B(mm)	C(mm)
10=100GF	4.3	3.1511	φ3.5	9.5	7.0
16=160GF	5.0	3.85	φ3.5	10.0	7.5
26=260GF	6.0	4.85	φ3.3	12.5	10.0
32=320GF	6.5	5.35	φ3.3	15.0	12.5
52=520GF	7.5	6.35	φ3.3		
	8.0	6.85	φ3.3		
	9.0	7.85	φ3.3		
	10.5	9.35	φ3.0		
	13.0	11.85	φ3.0		
	17.0	15.85	φ3.0		

SPECIFICATIONS

Rating	50mA 12V DC
Travel	0.25±0.1mm
Contact Resistance	≤ 100 mΩ
Operating temperature	-20℃ ~ 70℃(45% ~ 85% RH)
Operating Force	100±50/160±50/260±50/320±80/520±130gf
Operating Life	50,000 Cycles for 320/520gf, 100,000 Cycles for 260gf , 200,000 Cycles for 100/160gf

NO.	PARTS	MATERIALS	Q'TY	FINISH	TOLERANCE UNLESS SPECIFIED	DESCRIPTIONS OF REVISION	APPD.	
8					TOLERANCE UNLESS SPECIFIED WITHIN 1.5mm : ±0.1mm OVER 1.5mm : ±0.2mm	THESE DRAWINGS AND SPECIFICATIONS ARE THE PROPERTY OF DONGGUAN TIANDU ELECTRONICS CO.,LTD. AND SHALL NOT BE REPRODUCED, COPIED OR USED IN ANY MANNER WITHOUT THE PRIOR WRITTEN CONSENT OF DONGGUAN TIANDU ELECTRONICS CO., LTD		
7								
6	TRESTLE	SPCC	1	NICKEL PLATING				
5	KNOB	PPA	1	BLACK				
4	COVER	SPCC	1	NICKEL PLATING				
3	TERMINAL	BRASS(0.3T)	2	SILVERING	TITLE : TACT SWITCH	UNIT : mm	DRWG NO.: CMTDDZ-T6-6060BM-00	
2	CONTACT	SUS	1	SILVER COVERED	MODEL: T6-6060BM-XX-H-B-C	SCALE: 3:1	DWN. ERIC 2013-6-17	
1	BASE	PPA	1	BLACK	CMTDDZ 东莞市田都科技有限公司 DONGGUAN TIANDU TECHNOLOGY CO.,LTD.	CHK'D MAIKO	2013-6-17	
						APPD. Coco	2013-6-17	