

RoHS Compliant

规格说明: Specifications:

电气特性: Electrical:

1. 额定电流: Current Rating
1.5A/contact terminal
2. 额定电压: Voltage Rating
30V DC
3. 接触阻抗: Contact Resistance
30 milliohms MAX
4. 耐电压: Dielectric Withstanding Voltage:
500 V AC AT Sea Level
5. 绝缘阻抗: Insulation Resistance:
1000MEGA ohms MIN

物理性能: Mechanical:

1. 插拔力: Connector Mate and Unmate Force
Mate force: 3.57kgf(MAX)
Unmate force: 1.02kgf(MIN)
2. 端子保持力: Terminal Retention
1.0kgf(MIN)
3. 寿命: Durability
1500 CYCLES MIN

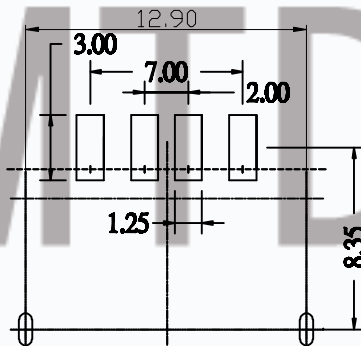
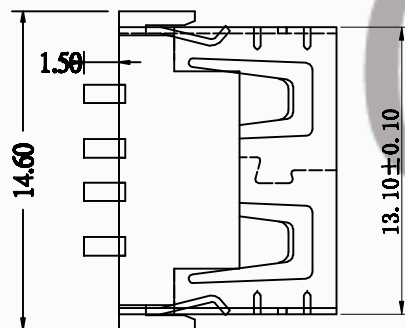
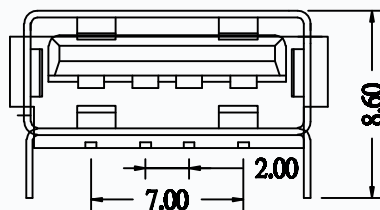
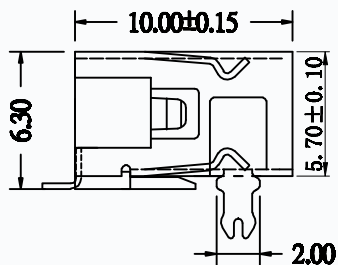

RECOMMENDED P. C. B LAYOUT

- T10-2F630AS-X X X X X X X X
- B=盐雾24H C=盐雾48H
 - 包装方式PACK:
2: 盘装 3: 管装 4: 载带
 - 端子电镀SPRING PLATING:
0: 镀金GF 5: 5u" 6: 15u" 8: 30u"
 - 端子材质SPRING CONTACT:
C: 黄铜 P: 磷铜
 - 外壳电镀SHELL PLATING:
N: 镀镍 T: 镀雾锡
 - 外壳材质SHELL:
S: 不锈钢 C: 黄铜 A: 冷轧钢板
 - 塑胶颜色HOUSING COLOUR:
W: 白色 B: 黑色 L: 蓝色 Y: 黄色 G: 绿色
 - 塑胶材质HOUSING:
0: PBT 3: LCP 6: PA-6T 9: PA-9T

CMTDDZ 东莞市田都科技有限公司 Dongguan Tiandu Technology Co., Ltd TEL: 0769-85384807 FAX: 0769-85384842		图号 (DWG NO)		单位 (UNIT): MM
		版本 (REV)	A/0	比例 (SCALE) 1:1
品名 (ITEM NO)	USB A/F 90度短体10.0直边贴片前2脚 6.3H	日期 (DATE)	2015.06.09	未注公差 TOLERANCE UNSPECIFIED I X ±0.30 I XX ±0.20 I XXX ±0.10 I* ±0.1 I X* ±0.2
料号 (PART NO)	T10-2F630AS-XXXXXX	设计 (DESIGN)	ERIC	
模号 (MODEL NO)	N/A	审核 (CHECKED)	~	
		核准 (APPROVED)		