

RoHS Compliant

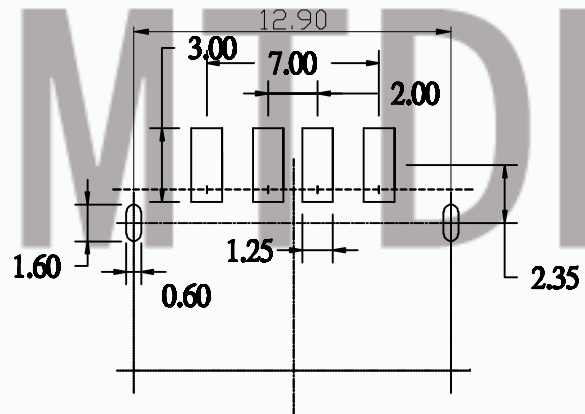
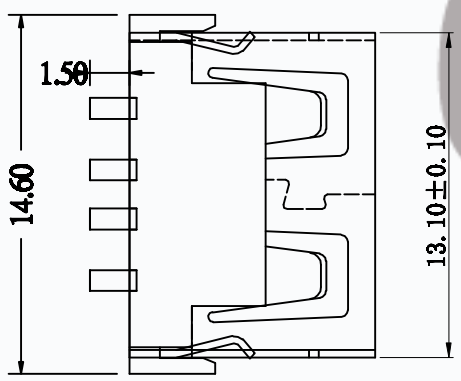
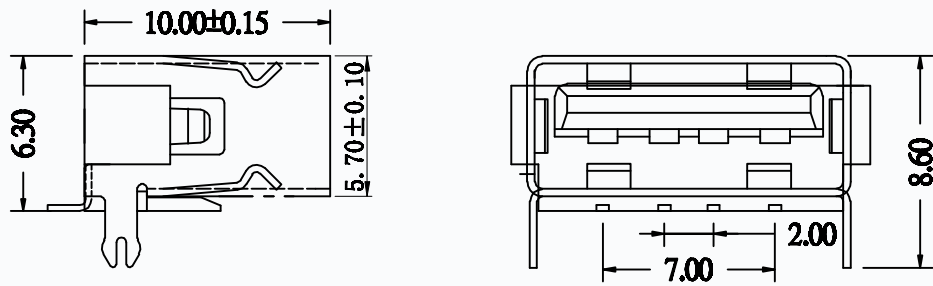

RECOMMENDED P.C.B LAYOUT

- T10-2F630BS-X X X X X X X X
- B=盐雾24H C=盐雾48H
 - 包装方式PACK: 2: 盘装 3:管装 4: 载带
 - 端子电镀SPRING PLATING: 0: 镀金GF 5:5u" 6:15u" 8:30u"
 - 端子材质SPRING CONTACT: C:黄铜 P:磷铜
 - 外壳电镀SHELL PLATING: N:镀镍 T:镀雾锡
 - 外壳材质SHELL: S:不锈钢 C:黄铜 A:冷轧钢板
 - 塑胶颜色HOUSING COLOUR: W:白色 B:黑色 L:蓝色 Y:黄色 G:绿色
 - 塑胶材质HOUSING: 0:PBT 3:LCP 6:PA-6T 9:PA-9T

规格说明: Specifications:

电气特性: Electrical:

1. 额定电流: Current Rating
1.5A/contact terminal
2. 额定电压: Voltage Rating
30V DC
3. 接触阻抗: Contact Resistance
30 milliohms MAX
4. 耐电压: Dielectric Withstanding Voltage:
500 V AC AT Sea Level
5. 绝缘阻抗: Insulation Resistance:
1000MEGA ohms MIN

物理性能: Mechanical:

1. 插拔力: Connector Mate and Unmate Force
Mate force: 3.57kgf(MAX)
Unmate force: 1.02kgf(MIN)
2. 端子保持力: Terminal Retention
1.0kgf(MIN)
3. 寿命: Durability
1500 CYCLES MIN

CMTDDZ 东莞市田都科技有限公司 Dongguan Tiandu Technology Co., Ltd TEL: 0769-85384807 FAX: 0769-85384842		图号 (DWG NO)		单位 (UNIT): MM
		版本 (REV)	A/0	比例 (SCALE) 1:1
品名 (ITEM NO)	USB A/F 短体10.0贴片直边后两脚 6.3H	日期 (DATE)	2015.06.09	未注公差 I X ±0.30 I XX ±0.20 I XXX ±0.10 I* ±0.1 I X* ±2°
料号 (PART NO)	T10-2F630BS-XXXXXXX	设计 (DESIGN)	ERIC	
模号 (MODEL NO)	N/A	审核 (CHECKED)	~	
		核准 (APPROVED)		