

CAD FILE:

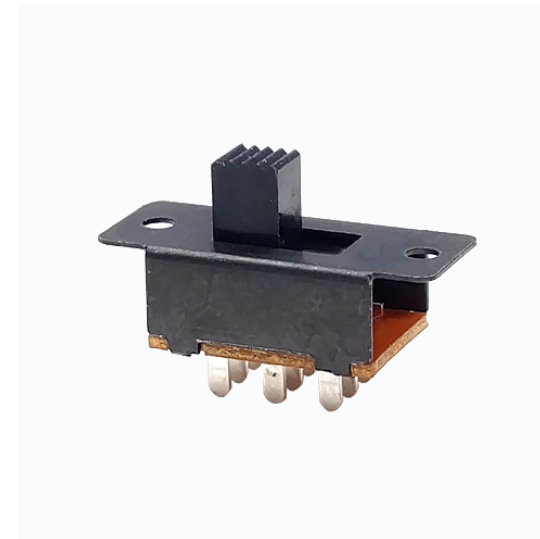

MODEL NO.	KNOB(G/VG)
T2-324001-GX	(2~15)mm

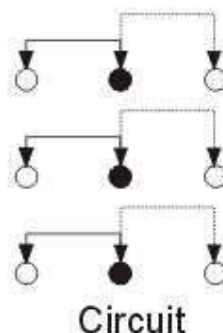
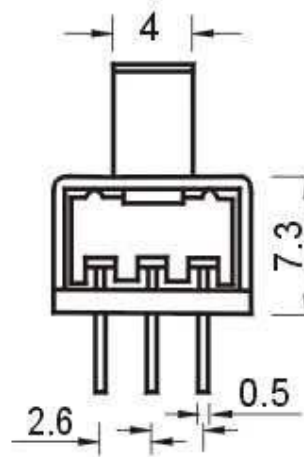
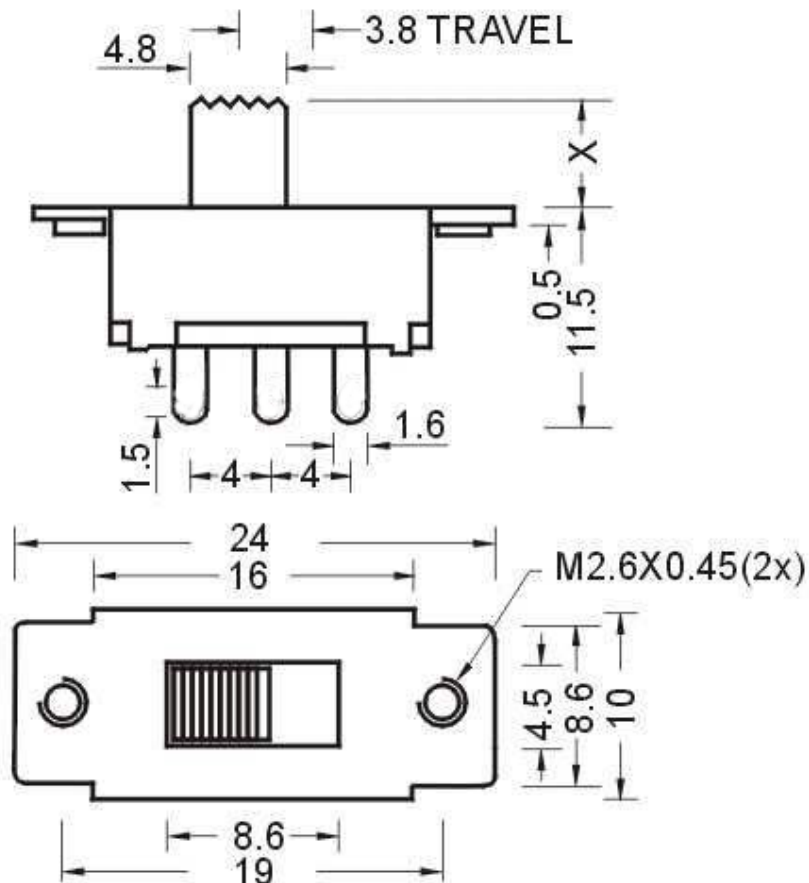

SPECIFICATIONS	
Rating	0.5A 50V DC
CIRCUIT	3P2T
Timing	NON-SHORTING
Travel	3.8mm
Contact Resistance	< 100 mΩ
Operating Force	250gf ± 100gf
Operating Life	10,000 cycles

NO.	PARTS	MATERIALS	Q'TY	FINISH	TOLERANCE UNLESS SPECIFIED	DESCRIPTIONS OF REVISION	APPD.
8					WITHIN 1.5mm : ±0.1mm OVER 1.5mm : ±0.2mm	THESE DRAWINGS AND SPECIFICATIONS ARE THE PROPERTY OF DONGGUAN TIANDU ELECTRONICS CO.,LTD. AND SHALL NOT BE REPRODUCED, COPIED OR USED IN ANY MANNER WITHOUT THE PRIOR WRITTEN CONSENT OF DONGGUAN TIANDU ELECTRONICS CO., LTD	
7							
6	SPRING	STEEL STRIP	3	NATURAL			
5	CONTACT CLIP	BRASS STRIP	3	Ag PLATED			
4	TERMINAL	BRASS STRIP	9	Ag PLATED OVER Ni PLATED			
3	BASE	PHENOLIC RESIN	1	NATURAL			
2	FRAME	STEEL STRIP	1	BLACK			
1	KNOB	POM	1	BLACK			
					TITLE : VERTICAL SLIDE SWITCH	UNIT : mm	DRWG NO.: CMTDDZ-T2-324001-00
					MODEL: T2-324001-G	SCALE: 3:1	DWN. ERIC 2013-6-17
					CMTDDZ 东莞市田都电子有限公司 DONGGUAN TIANDU ELECTRONICS CO.,LTD.	CHK'D MAIKO 2013-6-17	
						APPD. Coco 2013-6-17	