

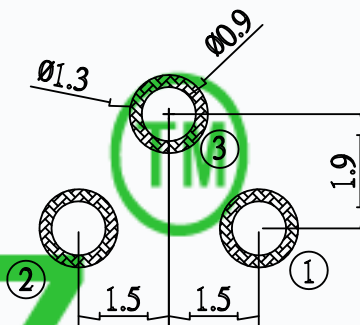

CAD FILE:

MODEL NO.	XX	H
T6-4545M-XX-H	10=100gf	3.8~9MM
	13=130gf	
	16=160gf	
	25=250gf	
	32=320gf	

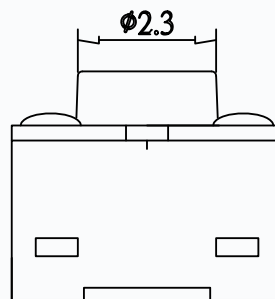
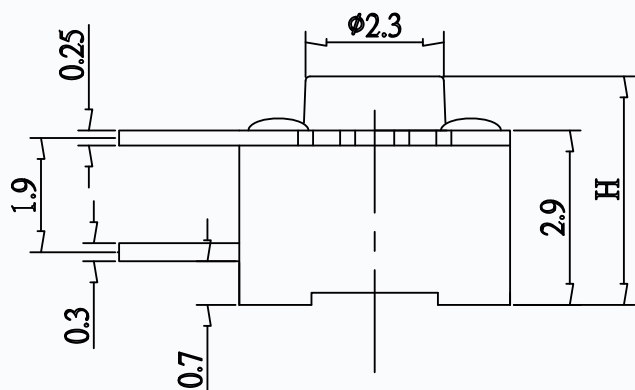
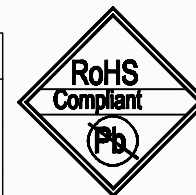

P.C.B. LAND PATTERN

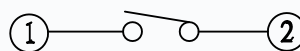
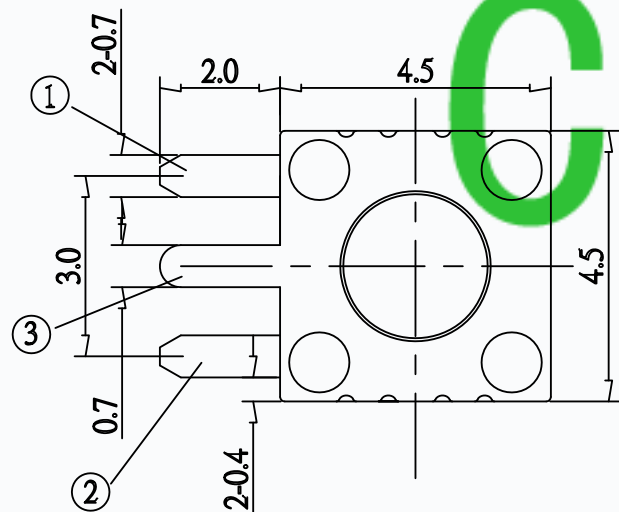

CIRCUIT DIAGRAM

CMTDDZ

SPECIFICATIONS

Rating	50mA 12V DC
Travel	0.25±0.1mm
Contact Resistance	≤ 100 mΩ
Operating temperature	-20℃ ~ 70℃(45% ~ 85% RH)
Operating Force	100±30gf/130±30gf/160±50gf/250±50gf/320±50gf
Operating Life	100,000 Cycles

8				
7				
6				
5	COVER	MILTD STEEL	1	PLATING NICKEL
4	KEYSTOKE	NYLON	1	BLACK/WHITE
3	TERMINAL	BRASS	2	PLATING Ag
2	CONTACT	SUS	1	Ag CLAD
1	BASE	NYLON	1	BLACK
NO.	PARTS	MATERIALS	Q'TY	FINISH

TOLERANCE UNLESS SPECIFIED		THESE DRAWINGS AND SPECIFICATIONS ARE THE PROPERTY OF DONGGUAN TIANDU ELECTRONICS CO.,LTD. AND SHALL NOT BE REPRODUCED, COPIED OR USED IN ANY MANNER WITHOUT THE PRIOR WRITTEN CONSENT OF DONGGUAN TIANDU ELECTRONICS CO., LTD		DESCRIPTIONS OF REVISION		APPD.	
WITHIN 1.5mm : ±0.1mm							
OVER 1.5mm : ±0.2mm							
TITLE : TACT SWITCH			UNIT : mm	DRWG NO.: CMTDDZ-T6-4545M-00			
MODEL: T6-4545M-XX-H			SCALE: 3:1	DWN.	ERIC	2013-6-17	
CMTDDZ 东莞市田都电子有限公司			DONGGUAN TIANDU ELECTRONICS CO.,LTD.		CHK'D	MAIKO	2013-6-17
					APPD.	Coco	2013-6-17