

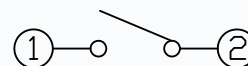

CAD FILE:

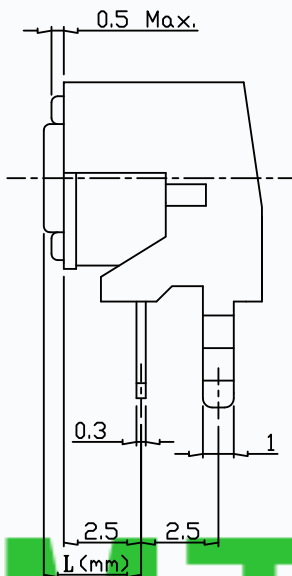
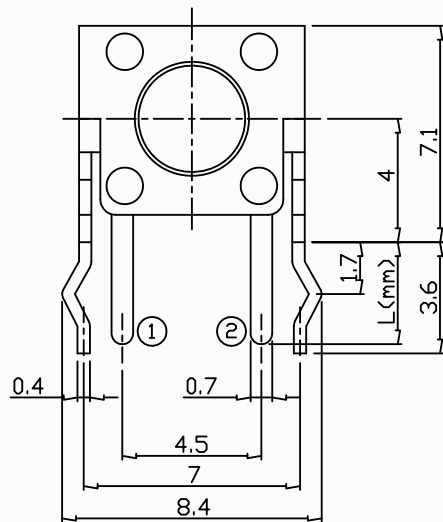

CIRCUIT DIAGRAM

MODEL NO.	T6-6060GM-XX-H		
XX	H(mm)	L(mm)	A(mm)
10=100GF	4.3	3.15	φ3.5
16=160GF	5.0	3.85	φ3.5
26=260GF	6.0	4.85	φ3.3
32=320GF	6.5	5.35	φ3.3
52=520GF	7.5	6.35	φ3.3
	8.5	7.35	φ3.3
	9.0	7.85	φ3.3
	11.0	9.85	φ3.0
	13.0	11.85	φ3.0
	15.0	13.85	φ3.0

CMTDDZ

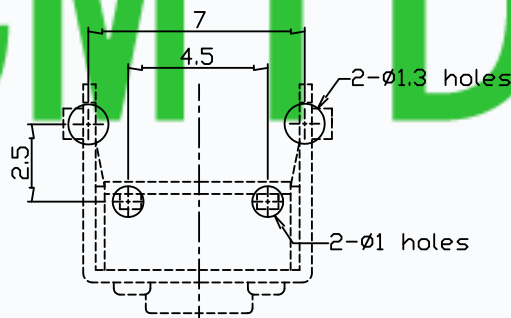
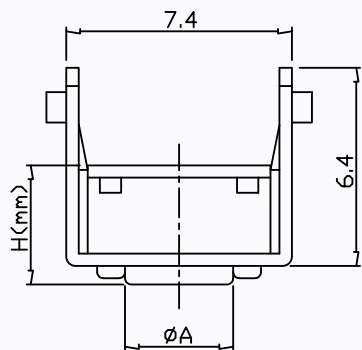

P.C.B. LAND PATTERN

SPECIFICATIONS

Rating	50mA 12V DC
Travel	0.25±0.1mm
Contact Resistance	≤ 100 mΩ
Operating temperature	-20℃ ~ 70℃ (45% ~ 85% RH)
Operating Force	100±50/160±50/260±50/320±80/520±130gf
Operating Life	50,000 Cycles for 320/520gf, 100,000 Cycles for 260gf, 200,000 Cycles for 100/160gf

NO.	PARTS	MATERIALS	Q'TY	FINISH
8				
7				
6				
5	KNOB	PPA	1	BLACK
4	COVER	SPCC	1	NICKEL PLATING
3	TERMINAL	BRASS(0.3T)	2	SILVERING
2	CONTACT	SUS	1	SILVER COVERED
1	BASE	PPA	1	BLACK

TOLERANCE
UNLESS SPECIFIED
WITHIN 1.5mm : ±0.1mm
OVER 1.5mm : ±0.2mm

THESE DRAWINGS AND SPECIFICATIONS ARE THE PROPERTY OF DONGGUAN TIANDU ELECTRONICS CO.,LTD. AND SHALL NOT BE REPRODUCED, COPIED OR USED IN ANY MANNER WITHOUT THE PRIOR WRITTEN CONSENT OF DONGGUAN TIANDU ELECTRONICS CO., LTD

DESCRIPTIONS OF REVISION APPD.

TITLE : TACT SWITCH		UNIT : mm	DRWG NO.: CMTDDZ-T6-6060GM-00		
MODEL: T6-6060GM-XX-H		SCALE: 3:1	DWN.	ERIC	2013-6-17
CMTDDZ	东莞市田都电子有限公司 DONGGUAN TIANDU ELECTRONICS CO.,LTD.	CHK'D	MAIKO	2013-6-17	
		APPD.	Coco	2013-6-17	