

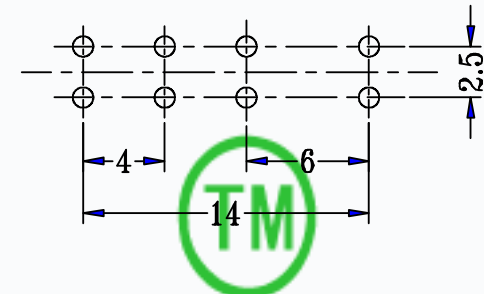

CAD FILE:

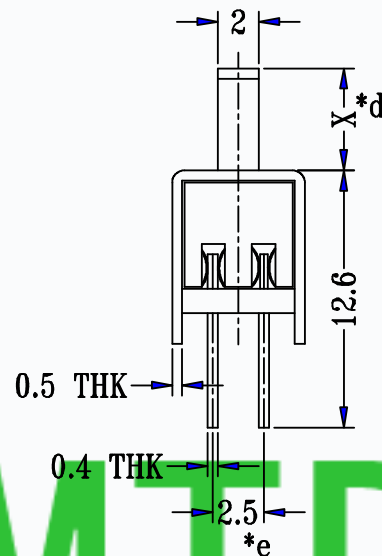

MODEL NO.	KNOB(X)
T2-234006-X	(2~15)mm

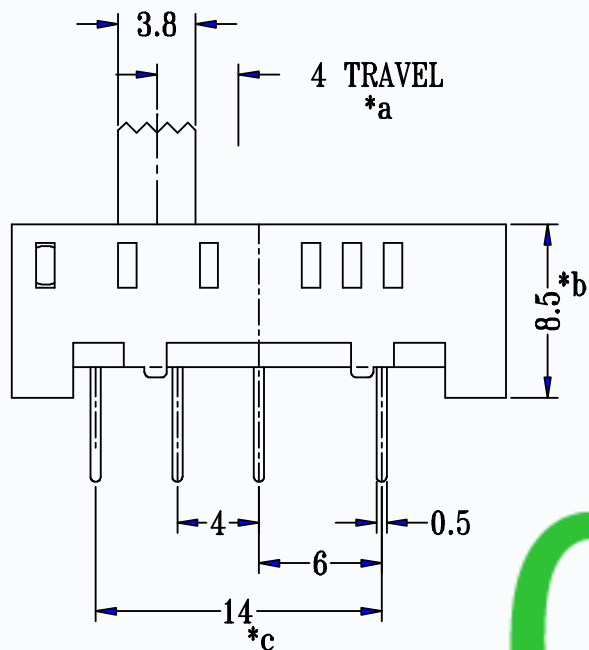

CMTDDZ

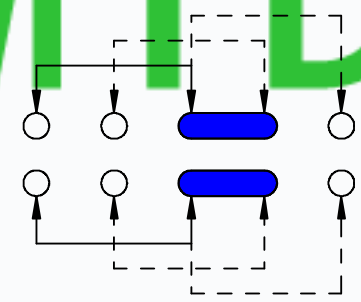
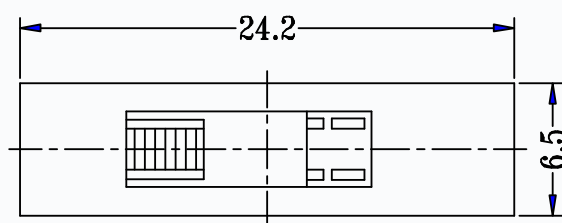

SCHEMATIC (NON-SHORTING)

P.C.B LAYOUT
BOTTOM VIEW

SPECIFICATIONS	
Rating	0.5A 50V DC
CIRCUIT	2P3T
Timing	NON-SHORTING
Travel	4.0mm
Contact Resistance	< 100 mΩ
Operating Force	250gf ± 100gf
Operating Life	10,000 cycles

NO.	PARTS	MATERIALS	Q'TY	FINISH	TOLERANCE	DESCRIPTIONS OF REVISION	APPD.
8					UNLESS SPECIFIED	THESE DRAWINGS AND SPECIFICATIONS ARE THE PROPERTY OF DONGGUAN TIANDU ELECTRONICS CO.,LTD. AND SHALL NOT BE REPRODUCED, COPIED OR USED IN ANY MANNER WITHOUT THE PRIOR WRITTEN CONSENT OF DONGGUAN TIANDU ELECTRONICS CO., LTD	
7	STEEL BALL	STEEL	1	NATURAL			
6	SPRING	STEEL WIRE	1	NATURAL	WITHIN 1.5mm : ±0.1mm		
5	CONTACT CLIP	PBS STRIP	2	Ag PLATED	OVER 1.5mm : ±0.2mm		
4	TERMINAL	BRASS STRIP	8	Ag PLATED			
3	BASE	PHENOLIC RESIN	1	NATURAL			
2	FRAME	STEEL STRIP	1	BLACK			
1	KNOB	POM	1	BLACK			
					TITLE : VERTICAL SLIDE SWITCH	UNIT : mm	DRWG NO.: CMTDDZ-T2-234006-00
					MODEL: T2-234006-X	SCALE: 3:1	DWN. ERIC 2013-6-17
					CMTDDZ 东莞市田都电子有限公司 DONGGUAN TIANDU ELECTRONICS CO.,LTD.	CHK'D MAIKO	2013-6-17
						APPD. Coco	2013-6-17