

CAD FILE:

MODEL NO.	XX	H(MM)
T6-6262CD-XX-H	13=130GF	2.5
	16=160GF	2.7
	25=250GF	3.1
		3.7
		4.3
		5.0

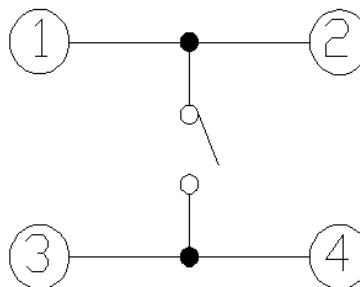

CIRCUIT DIAGRAM

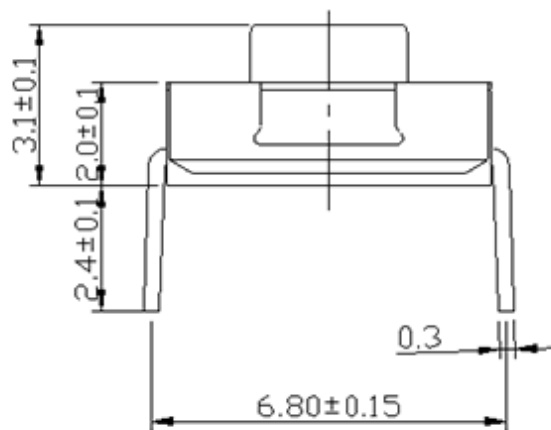
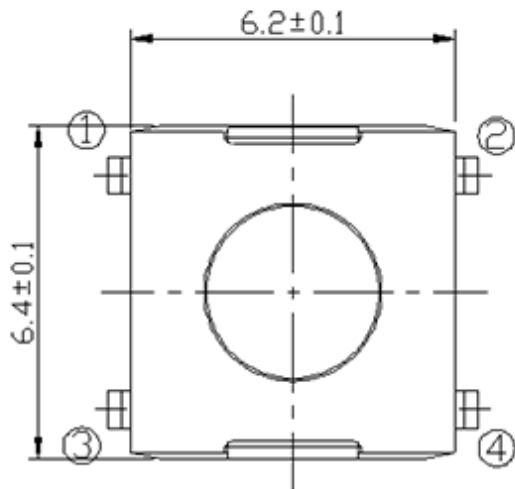
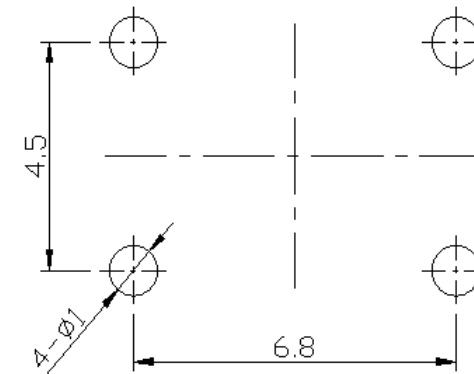

P.C.B LAND DIMENSION

SPECIFICATIONS	
Rating	50mA 12V DC
Travel	0.25±0.1mm
Contact Resistance	≤ 100 mΩ
Operating temperature	-20℃ ~ 70℃(45% ~ 85% RH)
Operating Force	130±50/160±50/250±50gf
Operating Life	50,000 Cycles

NO.	PARTS	MATERIALS	Q'TY	FINISH
8				
7				
6				
5	KNOB	NYLON	1	RED
4	COVER	SUS	1	NATURAL
3	TERMINAL	COPPER(0.3T)	4	PLATING SILVER
2	CONTACT	F.Ag/SUS	1	NATURAL
1	BASE	NYLON	1	BLACK

TOLERANCE UNLESS SPECIFIED		DESCRIPTIONS OF REVISION		APPD.
WITHIN 1.5mm	: ±0.1mm			
OVER 1.5mm	: ±0.2mm			
TITLE : TACT SWITCH		UNIT : mm	DRWG NO.: CMTDDZ-T6-6262CD-00	
MODEL: T6-6262CD-XX-H		SCALE: 3:1	DWN.	ERIC 2013-6-17
CMTDDZ 东莞市田都电子有限公司 DONGGUAN TIANDU ELECTRONICS CO.,LTD.			CHK'D	MAIKO 2013-6-17
			APPD.	Coco 2013-6-17

THESE DRAWINGS AND SPECIFICATIONS ARE THE PROPERTY OF DONGGUAN TIANDU ELECTRONICS CO.,LTD. AND SHALL NOT BE REPRODUCED, COPIED OR USED IN ANY MANNER WITHOUT THE PRIOR WRITTEN CONSENT OF DONGGUAN TIANDU ELECTRONICS CO., LTD