

CAD FILE:

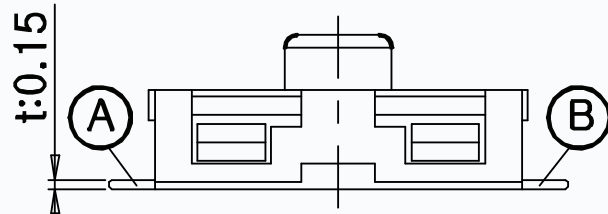

MODEL NO.	Contact arrangement	XX
T6-3862S-NC-XX	Normally closed	20=200gf
T6-3862S-NO-XX	Normally open	

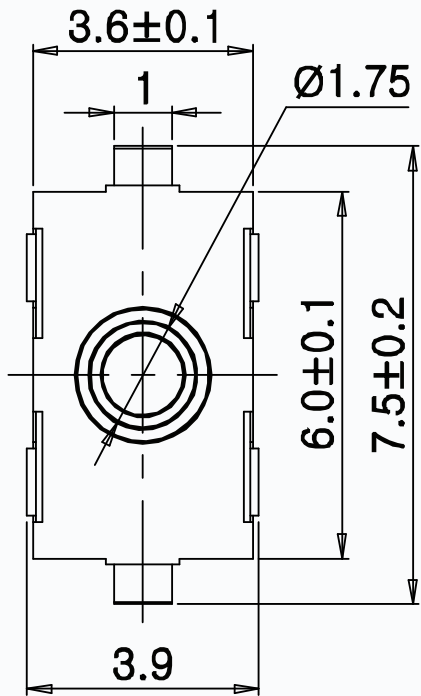
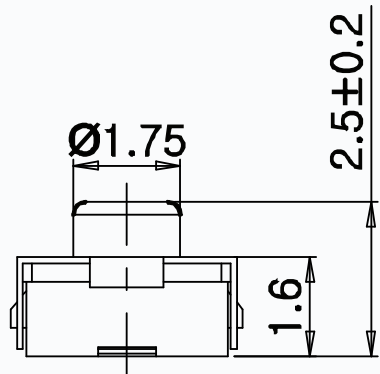
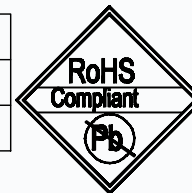

**CMTDDZ**



CIRCUIT DIAGRAM

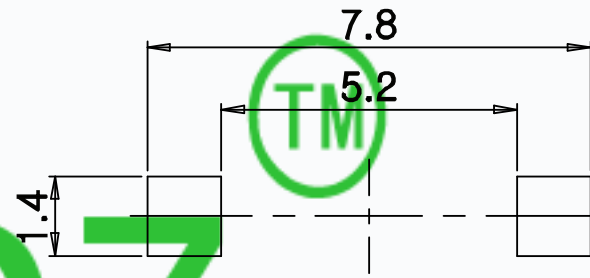

P.C.B. LAND PATTERN



CIRCUIT DIAGRAM

SPECIFICATIONS

Rating	50mA 32V DC
Travel	0.25±0.1mm
Contact Resistance	≤ 100 mΩ
Operating temperature	-20°C ~ 70°C ( 45% ~ 85% RH )
Operating Force	200±50gf
Operating Life	100,000 Cycles

8				
7				
6				
5	COVER	SUS	1	NATURAL
4	KNOB	SILICA GEL	1	BLUE
3	TERMINAL	PHOSPHOR BRONZE	2	PLATING SILVER
2	CONTACT	F.Ag/SUS	2	PLATING SILVER
1	BASE	NYLON	1	BLACK
NO.	PARTS	MATERIALS	Q'TY	FINISH

TOLERANCE UNLESS SPECIFIED		THESE DRAWINGS AND SPECIFICATIONS ARE THE PROPERTY OF DONGGUAN TIANDU ELECTRONICS CO.,LTD. AND SHALL NOT BE REPRODUCED, COPIED OR USED IN ANY MANNER WITHOUT THE PRIOR WRITTEN CONSENT OF DONGGUAN TIANDU ELECTRONICS CO., LTD		DESCRIPTIONS OF REVISION		APPD.
WITHIN 1.5mm : ±0.1mm						
OVER 1.5mm : ±0.2mm						
TITLE : TACT SWITCH			UNIT : mm	DRWG NO.: CMTDDZ-T6-3862S-00		
MODEL: T6-3862S-NC/NO-XX			SCALE: 3:1	DWN.	ERIC	2013-6-17
<b>CMTDDZ 东莞市田都电子有限公司</b>				CHK'D	MAIKO	2013-6-17
DONGGUAN TIANDU ELECTRONICS CO.,LTD.				APPD.	Coco	2013-6-17