

CAD FILE:

MODEL NO.	XX	H(mm)
T6-6060BS-XX-H	18=180GF	4.3
	25=250GF	5
	30=300GF	

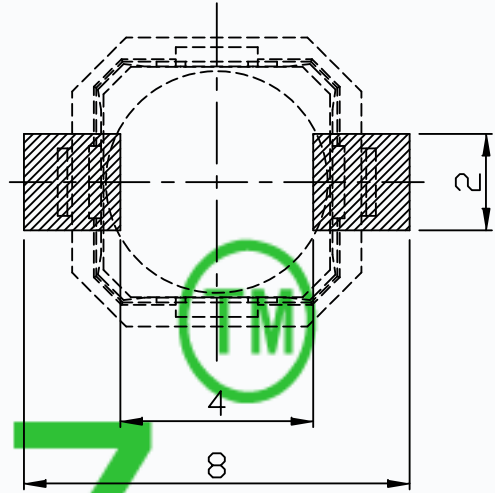
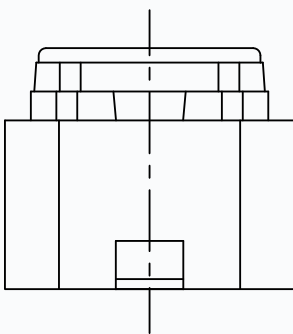
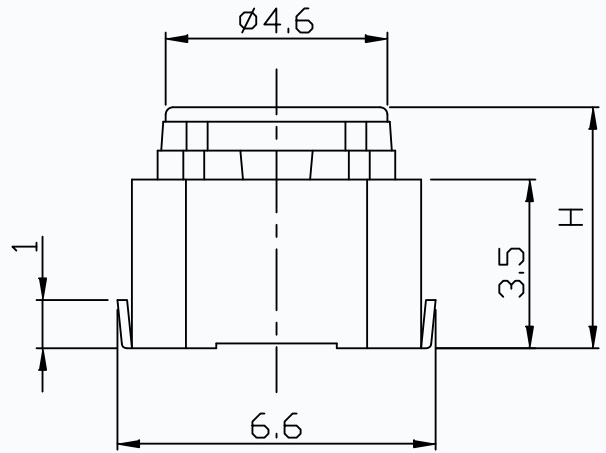
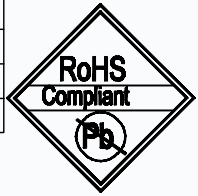

P.C.B. LAND PATTERN

CMTDDZ

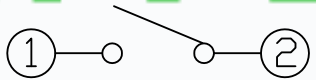
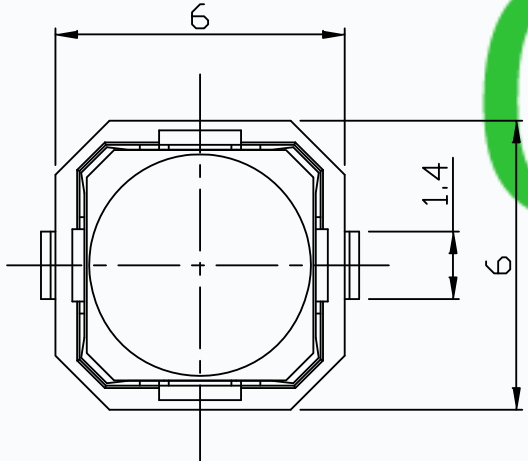

CIRCUIT DIAGRAM

SPECIFICATIONS	
Rating	0.1A 12V DC
Travel	1.3±0.3mm
Contact Resistance	≤ 100 mΩ
Operating temperature	-20℃ ~ 70℃( 45% ~ 85% RH )
Operating Force	180±30/200±30/300±30gf
Operating Life	100,000 Cycles
Ip Rating	IP66

NO.	PARTS	MATERIALS	Q'TY	FINISH
8				
7				
6				
5	KNOB	LCP	1	BLACK
4	WATERPROOF SILICONE	SILICA GEL	1	BLACK
3	TERMINAL	PHOSPHOR BRONZE	2	PLATING SILVER
2	CONTACT	PHOSPHOR BRONZE	1	Ag Clad
1	BASE	LCP	1	BLACK

TOLERANCE UNLESS SPECIFIED WITHIN 1.5mm : ±0.1mm OVER 1.5mm : ±0.2mm	THESE DRAWINGS AND SPECIFICATIONS ARE THE PROPERTY OF DONGGUAN TIANDU ELECTRONICS CO.,LTD. AND SHALL NOT BE REPRODUCED, COPIED OR USED IN ANY MANNER WITHOUT THE PRIOR WRITTEN CONSENT OF DONGGUAN TIANDU ELECTRONICS CO., LTD	DESCRIPTIONS OF REVISION	APPD.
TITLE : WATERPROOF SWITCH		UNIT : mm	DRWG NO.: CMTDDZ-T6-6262BS-00
MODEL: T6-6060BS-XX-H		SCALE: 3:1	DWN. ERIC 2013-6-17
CMTDDZ 东莞市田都电子有限公司 DONGGUAN TIANDU ELECTRONICS CO.,LTD.		CHK'D	MAIKO 2013-6-17
		APPD.	Coco 2013-6-17