

CAD FILE:

MODEL NO.	XX
T6-3760BS-XX	16=160GF
	26=260GF

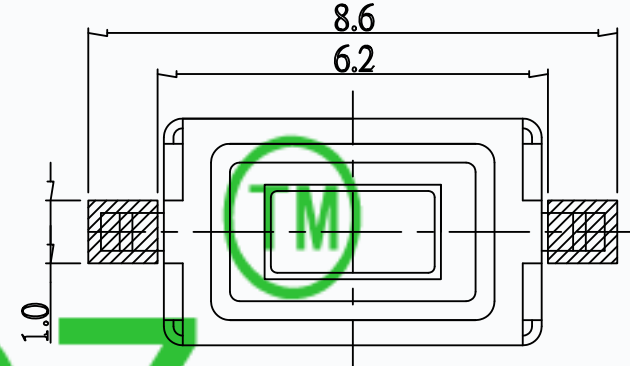

P.C.B. LAND PATTERN

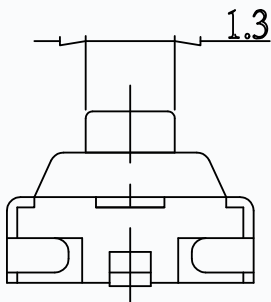
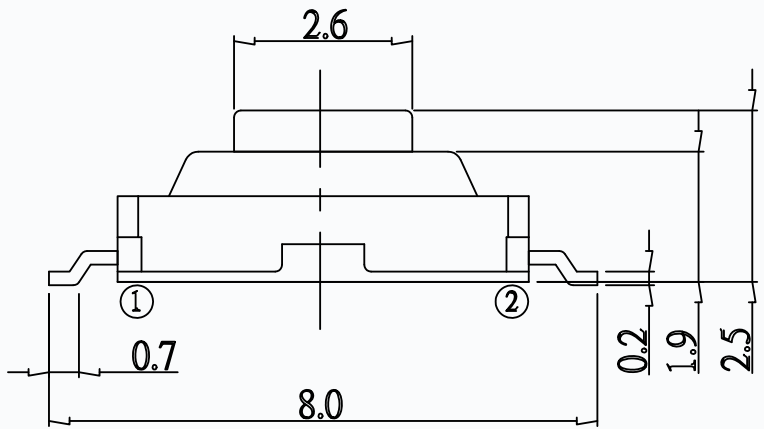
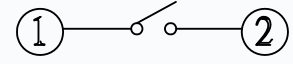
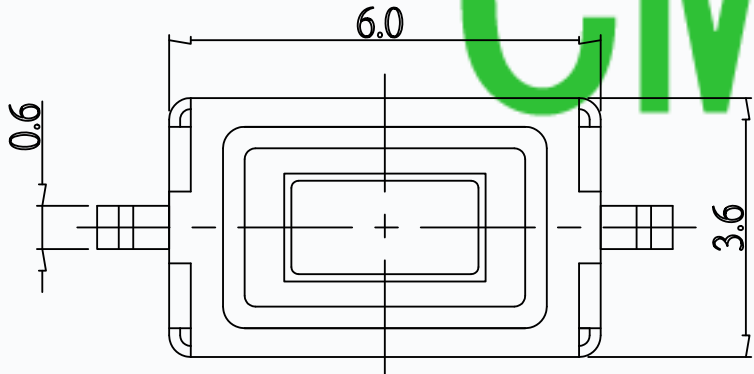

CIRCUIT DIAGRAM

SPECIFICATIONS

Rating	50mA 12V DC
Travel	0.25±0.05mm
Contact Resistance	≤ 100 mΩ
Operating temperature	-20℃ ~ 70℃( 45% ~ 85% RH )
Operating Force	160±50gf/260±50gf
Operating Life	20,000 Cycles for 260gf 50,000 Cycles for 160gf

NO.	PARTS	MATERIALS	Q'TY	FINISH
8				
7				
6				
5	COVER	SHEET LRON	1	PLATING NICKEL
4	KEYSTOKE	NYLON	1	WHITE
3	TERMINAL	BRASS(0.20t)	2	Ag-PLATED
2	CONTACT	STAINLESS STEEL	1	Ag-PLATED
1	BASE	NYLON	1	BLACK

TOLERANCE UNLESS SPECIFIED		THESE DRAWINGS AND SPECIFICATIONS ARE THE PROPERTY OF DONGGUAN TIANDU ELECTRONICS CO.,LTD. AND SHALL NOT BE REPRODUCED, COPIED OR USED IN ANY MANNER WITHOUT THE PRIOR WRITTEN CONSENT OF DONGGUAN TIANDU ELECTRONICS CO., LTD		DESCRIPTIONS OF REVISION		APPD.
WITHIN 1.5mm : ±0.1mm OVER 1.5mm : ±0.2mm						
TITLE : TACT SWITCH			UNIT : mm	DRWG NO.: CMTDDZ-T6-3760BS-00		
MODEL: T6-3760BS-XX			SCALE: 3:1	DWN.	ERIC	2013-6-17
CMTDDZ 东莞市田都电子有限公司				CHK'D	MAIKO	2013-6-17
DONGGUAN TIANDU ELECTRONICS CO.,LTD.				APPD.	Coco	2013-6-17