

CAD FILE:

MODEL NO.	XX	H
T6-3030CS-XX-H	16=160gf	1.5MM
	25=250gf	2.0MM

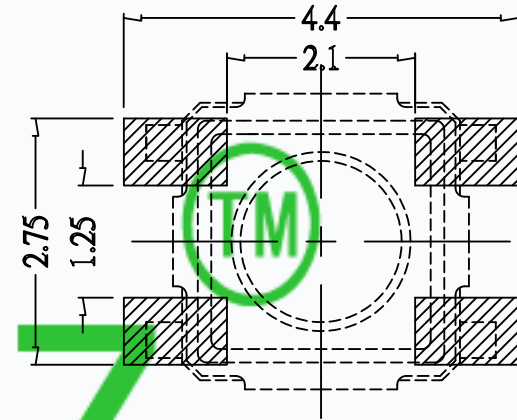

P.C.B. LAND PATTERN

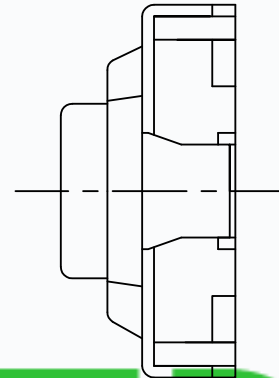
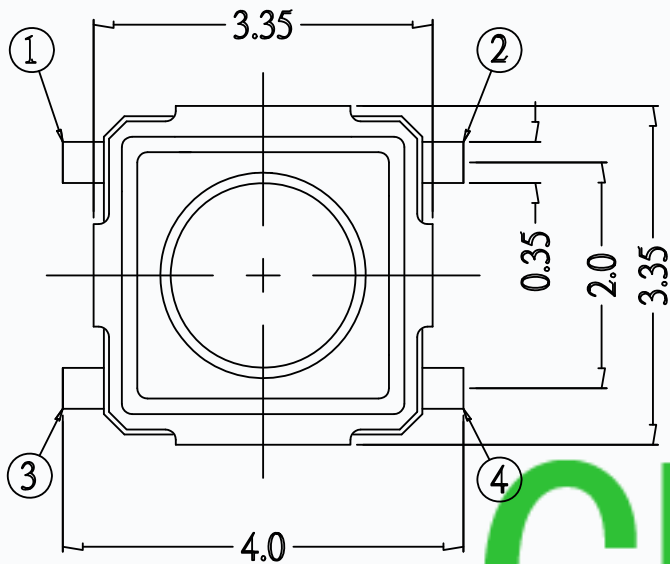
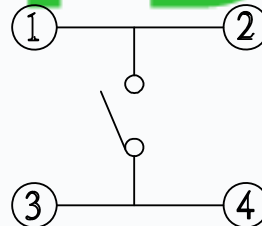
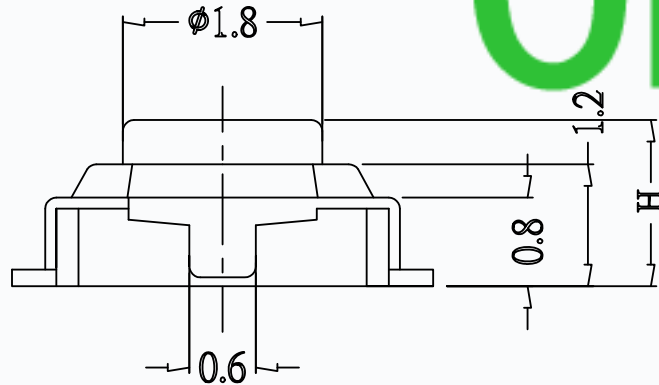

CIRCUIT DIAGRAM

SPECIFICATIONS

Rating	50mA 12V DC
Travel	0.15±0.05mm
Contact Resistance	≤ 100 mΩ
Operating temperature	-20℃ ~ 70℃(45% ~ 85% RH)
Operating Force	160±30gf/250±50gf
Operating Life	100,000 Cycles

NO.	PARTS	MATERIALS	Q'TY	FINISH
8				
7				
6	COVER	SPCC	1	NATURAL
5	KEYSTOKE	NYLON	1	WHITE
4	DUST COVER	KAPTON FILM	1	YELLOW
3	TERMINAL	PHOSPHOR BRONZE	4	PLATING SILVER
2	CONTACT	F.Ag/SUS	1	NATURAL
1	BASE	NYLON	1	BLACK

TOLERANCE UNLESS SPECIFIED WITHIN 1.5mm : ±0.1mm OVER 1.5mm : ±0.2mm	THESE DRAWINGS AND SPECIFICATIONS ARE THE PROPERTY OF DONGGUAN TIANDU ELECTRONICS CO.,LTD. AND SHALL NOT BE REPRODUCED, COPIED OR USED IN ANY MANNER WITHOUT THE PRIOR WRITTEN CONSENT OF DONGGUAN TIANDU ELECTRONICS CO., LTD	DESCRIPTIONS OF REVISION	APPD.
TITLE : TACT SWITCH		UNIT : mm	DRWG NO.: CMTDDZ-T6-3030CS-00
MODEL: T6-3030CS-XX-H		SCALE: 3:1	DWN. ERIC 2013-6-17
CMTDDZ 东莞市田都电子有限公司		CHK'D MAIKO	2013-6-17
DONGGUAN TIANDU ELECTRONICS CO.,LTD.		APPD. Coco	2013-6-17