

CIRCUIT DIAGRAM

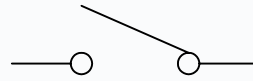

P.C.B DIMENSION

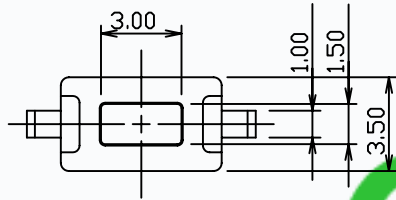
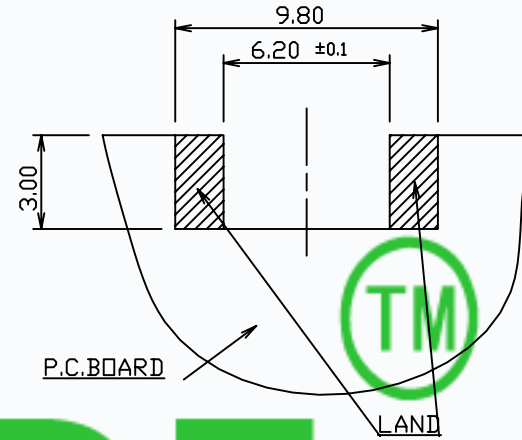

# CMTDDZ

NOTE

1. OPERATING FORCE : 180±50gf
2. TRAVEL : 0.25 +0.2/-0.1
3. CONTACT RESISTANCE : 100mΩ max.
4. GENERAL TOLERANCE : ±0.3

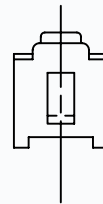
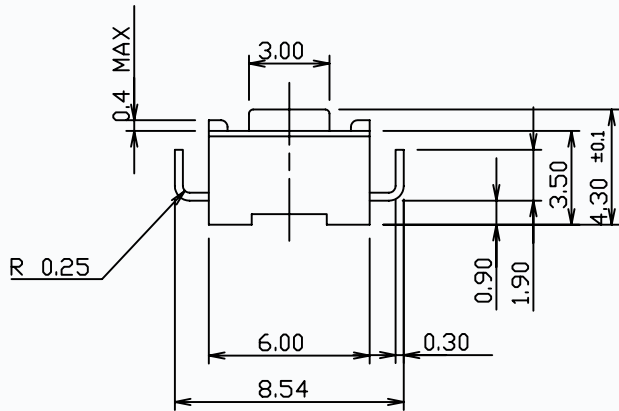

NO	PART NAME	Q'TY	MATERIAL	REMARKS
①	CASE	1	NYLON46	
②	STEM	1	NYLON 46	BLACK
③	COVER	1	SUS304-H	
④	TERMINAL	1	C2680R-EH	Ag 1.00μ
⑤	C/PLATE	1	SUS301-EH	Ag 0.5μ

No.	PART NAME	Q'TY	MATERIAL	SIZE	TREAT.	REMARKS
△			UNIT	SCALE		MODEL
△			3RD ANGLE PROJECTION	m/m		
△			APPROVED	CHECKED	DESIGNED	DWG.NAME
△						DWG.NO.
△						
NO.	DATE	NOTE	SIGN			