

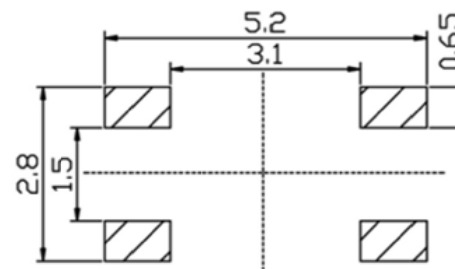

CAD FILE:

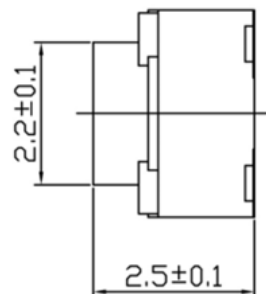

P.C.B. LAND PATTERN

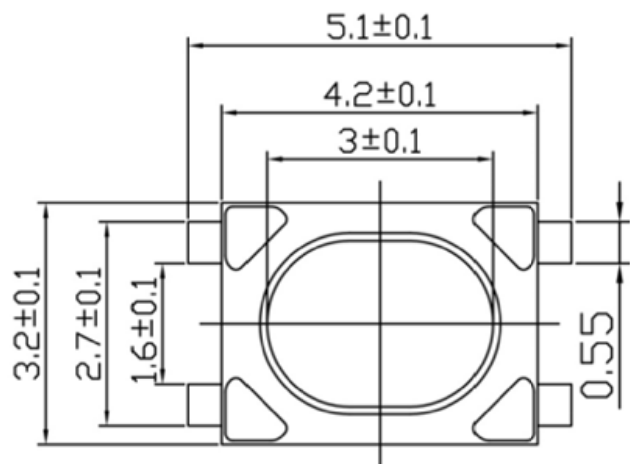
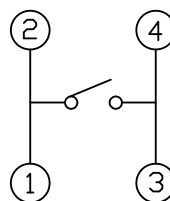
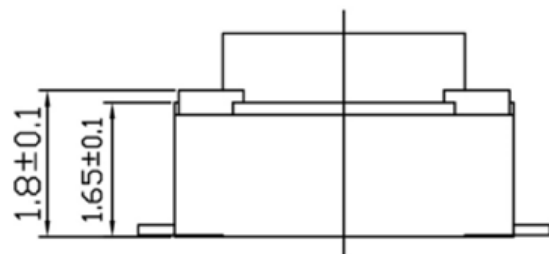

CIRCUIT DIAGRAM

MODEL NO.	XX
T6-3040AS-XX	16=160gf
	26=260gf
	32=320gf

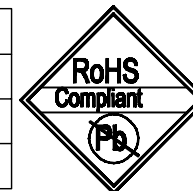

SPECIFICATIONS

Rating	50mA 16V DC
Travel	0.15±0.1mm
Contact Resistance	≤ 100 mΩ
Operating temperature	-20℃ ~ 70℃(45% ~ 85% RH)
Operating Force	160±50gf/260±50gf/320±50gf
Operating Life	100,000 Cycles for 160gf 50,000 Cycles for 260gf/320gf

8					TOLERANCE UNLESS SPECIFIED WITHIN 1.5mm : ±0.1mm OVER 1.5mm : ±0.2mm	THESE DRAWINGS AND SPECIFICATIONS ARE THE PROPERTY OF DONGGUAN TIANDU ELECTRONICS CO.,LTD. AND SHALL NOT BE REPRODUCED, COPIED OR USED IN ANY MANNER WITHOUT THE PRIOR WRITTEN CONSENT OF DONGGUAN TIANDU ELECTRONICS CO., LTD	DESCRIPTIONS OF REVISION		APPD.	
7										
6										
5	COVER	SUS	1	NATURAL						
4	KEYSTROKE	SILICA GEL	1	WHITE						
3	TERMINAL	PHOSPHOR BRONZE	4	PLATING SILVER						
2	CONTACT	F.Ag/SUS	1	PLATING SILVER						
1	BASE	LCP	1	WHITE						
NO.	PARTS	MATERIALS	Q'TY	FINISH	TITLE : TACT SWITCH MODEL: T6-3040AS-XX		UNIT : mm SCALE: 3:1	DRWG NO.: CMTDDZ-T6-3040AS-00 DWN. ERIC 2013-6-17 CHK'D MAIKO 2013-6-17 APPD. Coco 2013-6-17		

CMTDDZ 东莞市田都电子有限公司
DONGGUAN TIANDU ELECTRONICS CO.,LTD.