

1

2

3

4

5

6

REV.	ECN NO.	DESCRIPTION	DRWN	APPD.	DATE

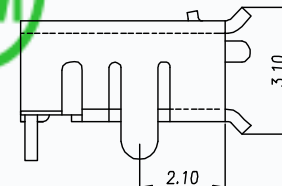
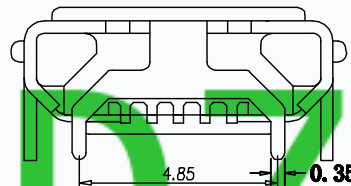
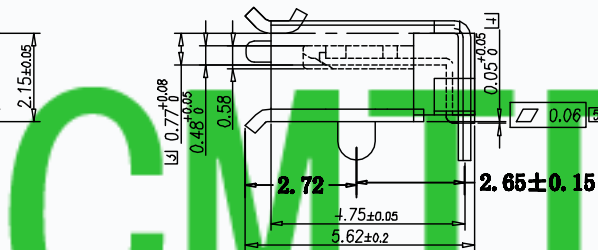
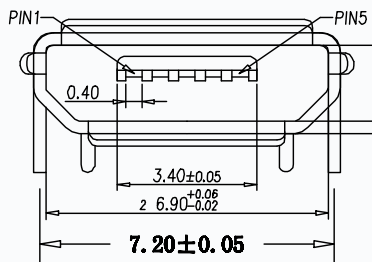
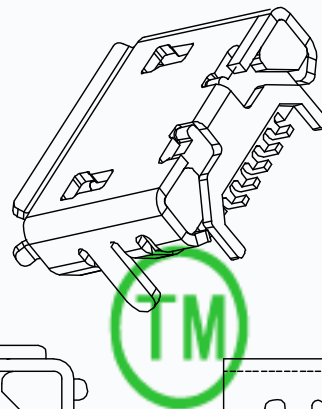
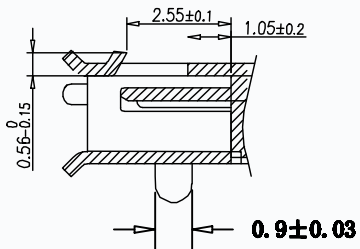
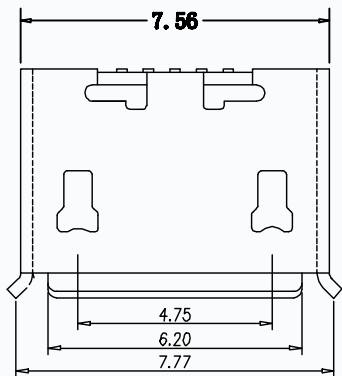

CMTDZ

- NOTES:**
MATERIAL:
 1.1 HOUSING: HIGH TEMPERATURE THERMOPLASTIC WITH G. F. UL94V-0
 1.2 CONTACT: COPPER ALLOY T=0.15mm
 1.3 SHELL: COPPER ALLOY, T=0.30mm
2. SPECIFICATION:
 2.1 CURRENT RATING: 1 A MAX
 2.2 DIELECTRIC WITHSTANDING VOLTAGE: 100 V(ac) FOR 1min
 2.3 CONTACT RESISTANCE: 30 mΩ MAX.
 2.4 INSULATION RESISTANCE: 100 MΩ MIN.
 2.5 TOTAL MATING FORCE: 3.57 Kgf MAX.
 2.6 TOTAL UNMATING FORCE: 1.0Kgf MIN. AFTER 10000 INSERTION/EXTRACTION CYCLES
 2.7 TEMPERATURE RANGE: -30°C ~ +80°C

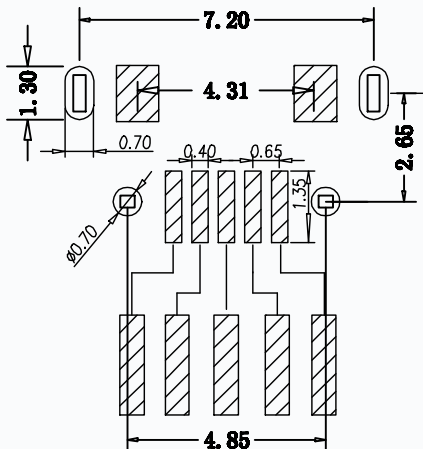
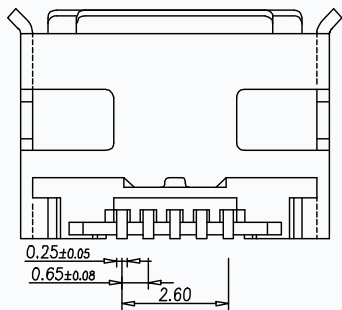

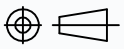
UNITS mm	SCALE 1:1	REV. X1	SHEET 1 OF 1	东莞市田都电子有限公司 DONGGUAN TIANDU ELECTRONICS CO.,LTD	
 GENERAL TOLERANCE 0. ±0.30 0.0 ±0.20 0.00 ±0.10 0.° ±4° 0.0° ±2°		DATE 2011-12-08	TITLE: MIRCO USB 5P B TYPE 四脚全插牛角型卷边		
		DR. MC	MAT'L SEE NOTES	FINISH SEE NOTES	
		APPD.	MODEL NO. p2 T10-05FB11	A	PART NO. CMTD006 USP-720-S04 SIZE A4

1

2

3

4

5

6