

RoHS DIRECTIVE

REV.	ECN. NO.	DESCRIPTION	DATE	DESIGN
------	----------	-------------	------	--------

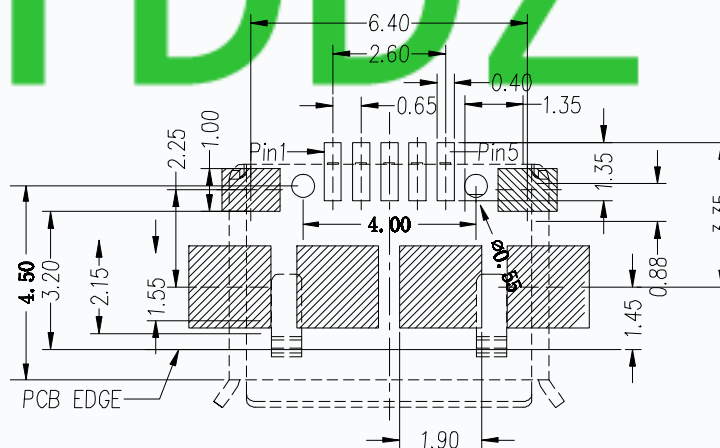
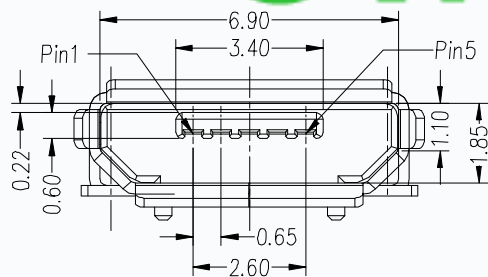
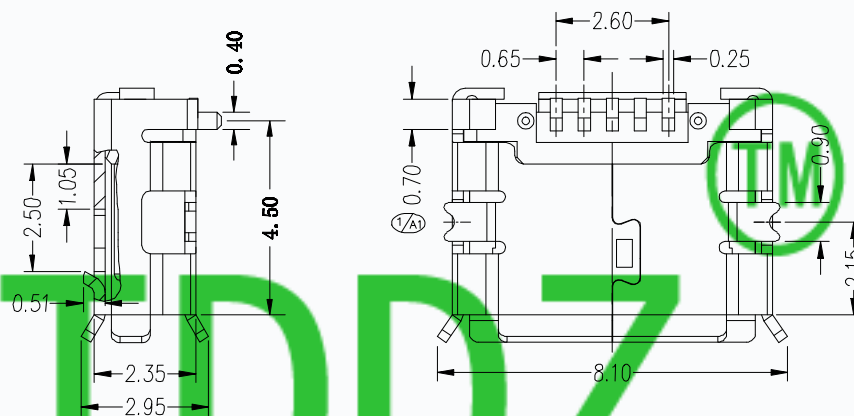
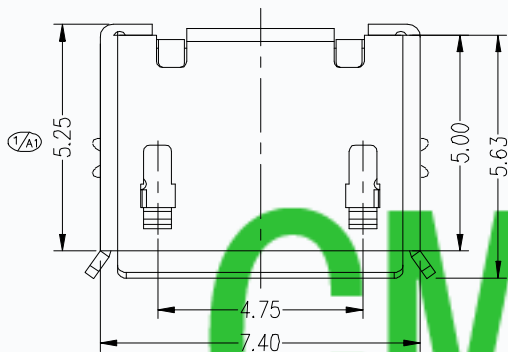
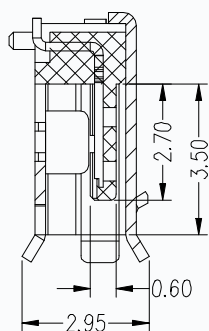
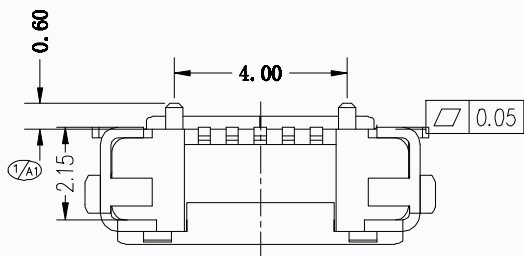

RECOMMENDED PCB LAYOUT

- NOTES:
- MATERIAL:
HOUSING: THERMOPLASTIC HIGH-TEMP UL94V-0 BLACK COLOR.
CONTACT: COPPER ALLOY.
SHELL: COPPER ALLOY.
 - FINISH:
CONTACT: 50u"~80u" Ni/G.F PLATED OVER ALL
SHELL: 50u"~80u" Ni/80u" MIN. MATTE Tin PLATED OVER ALL
 - APPLIED TO IR SOLDERING PROCESS.
 - SPECIFICATION:
4.1. ELECTRICAL CHARACTERISTICS
CONTACT CURRENT RATING: 1A MIN.
VOLTAGE RATING: 30V AC rms.
CONTACT RESISTANCE: 30mΩ MAX.
DIELECTRIC WITHSTANDING VOLTAGE:
UNWATER CONTACT 100V AC rms, 60MHZ FOR 1 MINUTE.
INSULATION RESISTANCE: 1000MΩ MIN. 100V DC
TEMPERATURE RANGE: -20°C TO +85°C
4.2. MECHANICAL:
INSERTION FORCE: 35N MAX.
WITHDRAWAL FORCE: 8N MIN.
DURABILITY: 10,000 CYCLES

THESE DRAWINGS AND SPECIFICATIONS ARE THE PROPERTY OF DONGGUAN TIANDU ELECTRONICS CO., LTD. AND SHALL NOT BE REPRODUCED, COPIED OR USED IN ANY MANNER WITHOUT THE PRIOR WRITTEN CONSENT OF DONGGUAN TIANDU ELECTRONICS CO., LTD

UNITS	mm	NAME (INTENDED USE)	USB
MAT'L 材质		MODEL NO.	T10-05FB07
FINISH 硬度		APPD:	
Q'TY 数量		CHKD:	
		DR:	MC 2011. 07. 03

东莞市田都电子有限公司 DONGGUAN TIANDU ELECTRONIC CO., LTD			
TITLE: MICRO USB 5P B型 四脚全贴卷边有柱 0.4			
DWG NO. : CMTD03-05-005-01			
角法 PROJ.	SCALE	SHEET	REV.
	1/1	页号	版本

DIM	TOL	DIM	TOL
X.	±0.35	X°	±1°
X.X	±0.25	X.X°	±0.5°
X.XX	±0.15	X.XX°	
X.XXX	±0.10	X.XXX°	