

REV.	ECN NO.	DESCRIPTION	DRAW	APPD.	DATE
A	---	新版发行	MC	SU	2018.03.16
B	---	新增料号	MC	SU	2019.03.18

装上CAP尺寸示意图 比例1:2

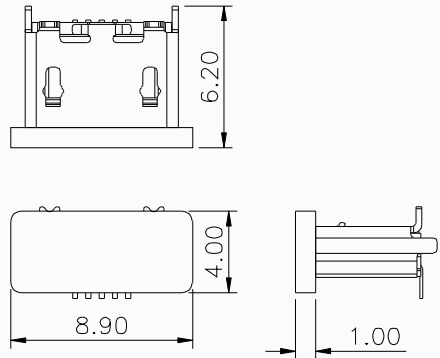

- SPECIFICATION:
- 1 CURRENT RATING: 0.5A(2.3.4CONTACT)/1.8A(1.5CONTACT) MAX.
  - 2 VOLTAGE: 30 VAC
  - 3 TEMPERATURE RANGE: -30 °C ~ 85 °C
  - 4 CONTACT RESISTANCE: 30 MILLIONHM MAX.
  - 5 DIELECTRIC WITHSTANDING VOLTAGE: 250 VAC r.m.s
  - 6 INSULATION RESISTNACE: 100 MEGOHMS MIN

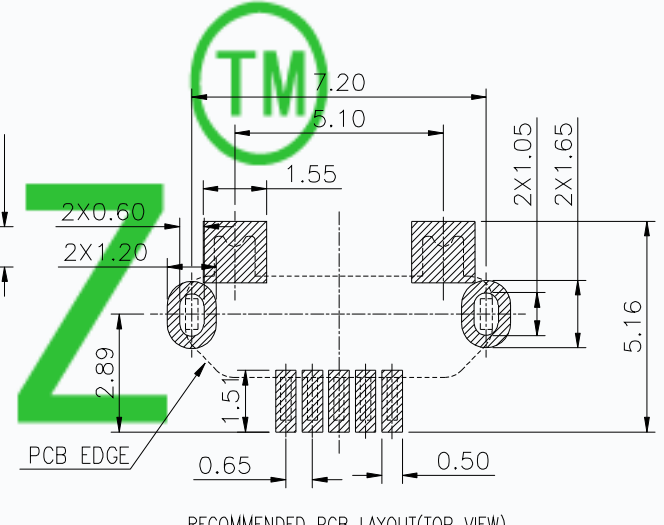
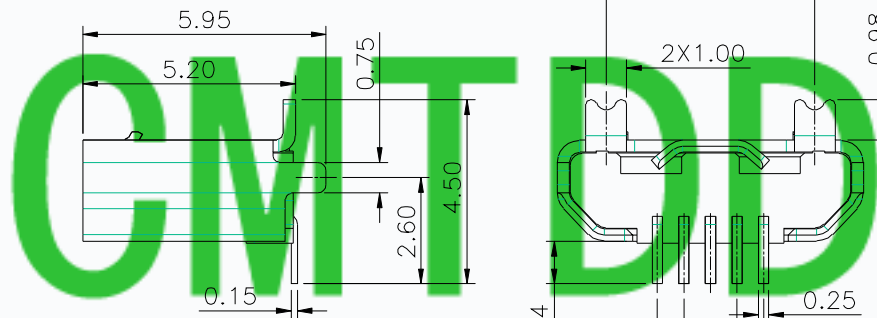
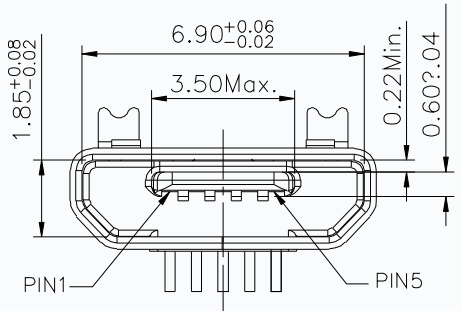
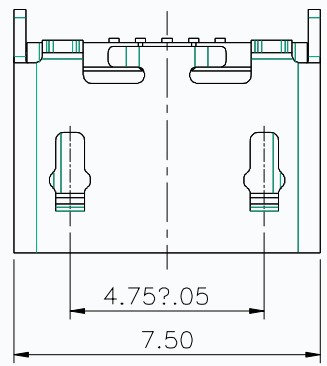

RECOMMENDED PCB LAYOUT(TOP VIEW)  
GENERAL TOLERANCES:±0.05

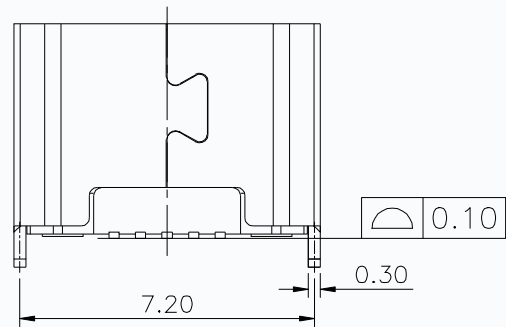

2	T10-05LS03-412	5P 直立SMT无翻边,外壳镀镍
1	T10-05LS03-312	5P 直立SMT无翻边,外壳雾锡
NO.	料号	规格

3	CONTACT	COPPER ALLOY(C2680 T=0.15mm)	Au 1u"/Ni Plated	IPCS
2	HOUSING	High temperature plastic(LCP)	BLACK	ISET
1	SHELL	STAINLESS STEEL(SUS304 T=0.30mm)	MATTE TIN 50u"/Ni Plated	IPCS
NO.	DESCRIPTION	MATERIAL	REMARKS	QTY
TOLERANCE		NAME(INTENDED USE) CUSTOMER DRAWING		<b>东莞市田都电子有限公司</b> DONGGUAN TIANDU ELECTRONIC CO.,LTD PART NO. T10-05LS03-XXX TITLE: MICRO USB 5P 直立SMT无翻边 APPD: DRAWG NO. 0101-4120 CHED: SCALE SHEET REV. DRAW: 1:1 1/1 B
X.X ±0.30	X.' ± 2'	PART NO.		
.XX ±0.20	.X' ± 1'	T10-05LS03-XXX		
.XXX ±0.10	.XX' ±0.5'	APPD:		
UNITS	mm	MATERILA		CHED:
FINISH		DRAW:		DRAW: