

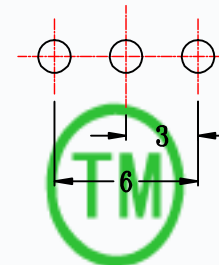

CAD FILE:

MODEL NO.	KNOB(G/VG)
T4-123023-G	(2~15)mm

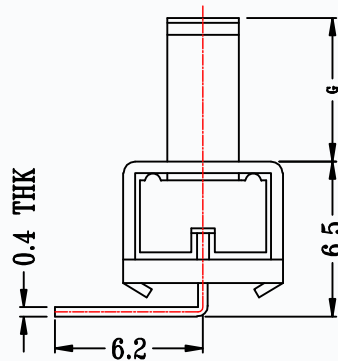
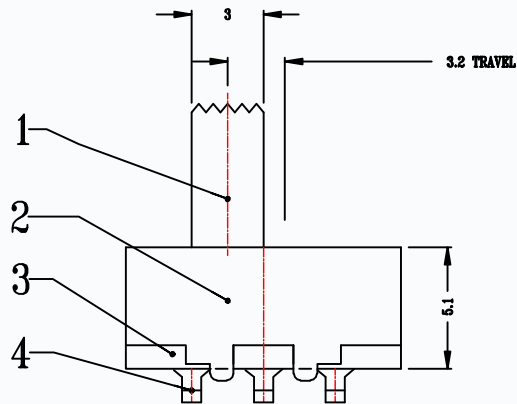

CMTDDZ

P.C.B. LAYOUT

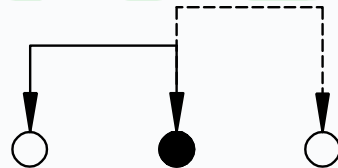
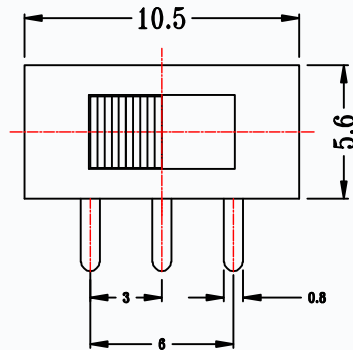

SCHEMATIC (NON-SHORTING)

SPECIFICATIONS	
Rating	0.5A 50V DC
CIRCUIT	1P2T
Timing	NON-SHORTING
Travel	3.2mm
Contact Resistance	< 100 mΩ
Operating Force	250gf ± 100gf
Operating Life	10,000 cycles

NO.	PARTS	MATERIALS	Q'TY	FINISH
8				
7				
6	SPRING	STEEL STRIP	1	NATURAL
5	CONTACT CLIP	PBS STRIP	1	Ag PLATED
4	TERMINAL	BRASS STRIP	3	Ag PLATED
3	BASE	PHENOLIC RESIN	1	NATURAL
2	FRAME	STEEL STRIP	1	NI PLATED
1	KNOB	POM	1	BLACK

TOLERANCE UNLESS SPECIFIED		THESE DRAWINGS AND SPECIFICATIONS ARE THE PROPERTY OF DONGGUAN TIANDU ELECTRONICS CO.,LTD. AND SHALL NOT BE REPRODUCED, COPIED OR USED IN ANY MANNER WITHOUT THE PRIOR WRITTEN CONSENT OF DONGGUAN TIANDU ELECTRONICS CO., LTD	DESCRIPTIONS OF REVISION		APPD.
WITHIN 1.5mm : ±0.1mm OVER 1.5mm : ±0.2mm					
TITLE : VERTICAL SLIDE SWITCH		UNIT : mm	DRWG NO.: CMTDDZ-T2-123021-00		
MODEL: T2-123021-G		SCALE: 3:1	DWN.	ERIC	2013-6-17
CMTDDZ 东莞市田都电子有限公司 DONGGUAN TIANDU ELECTRONICS CO.,LTD.		CHK'D		MAIKO	2013-6-17
		APPD.		Coco	2013-6-17