

CAD FILE:

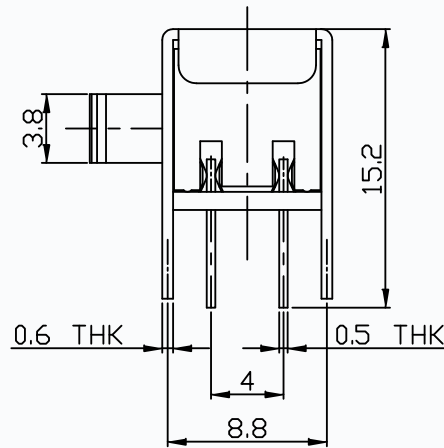

MODEL NO.	KNOB(G/VG)
T3-243001-G	(2~15)mm

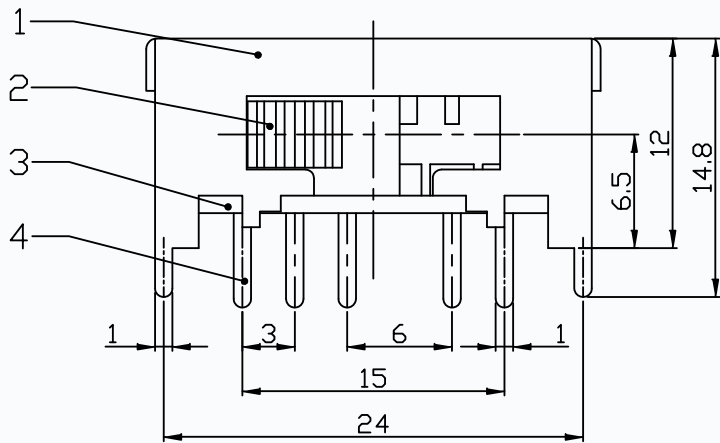
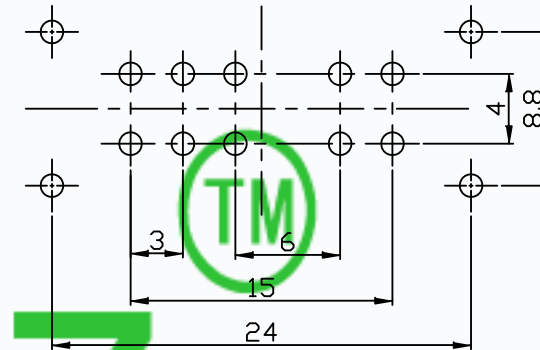

P.C.B. LAYOUT

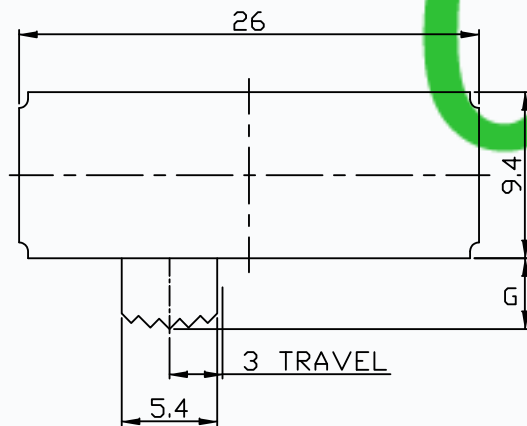

CMTDDZ

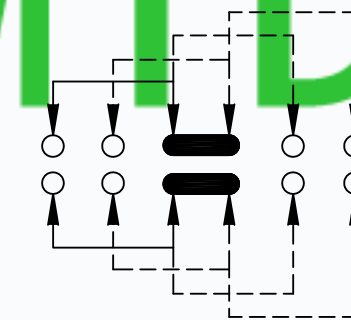

SCHEMATIC (NON-SHORTING)

SPECIFICATIONS

Rating	0.3A 50V DC
CIRCUIT	2P4T
Timing	NON-SHORTING
Travel	3.0mm
Contact Resistance	< 100 mΩ
Operating Force	250gf ± 100gf
Operating Life	10,000 cycles

NO.	PARTS	MATERIALS	Q'TY	FINISH
8				
7	STEEL BALL	STEEL	1	NATURAL
6	SPRING	STEEL WIRE	1	NATURAL
5	CONTACT CLIP	PBS STRIP	2	Ag PLATED
4	TERMINAL	BRASS STRIP	10	Ag PLATED
3	BASE	PHENOLIC RESIN	1	NATURAL
2	KNOB	POM	1	BLACK
1	FRAME	STEEL STRIP	1	NI PLATED

TOLERANCE UNLESS SPECIFIED		THESE DRAWINGS AND SPECIFICATIONS ARE THE PROPERTY OF DONGGUAN TIANDU ELECTRONICS CO.,LTD. AND SHALL NOT BE REPRODUCED, COPIED OR USED IN ANY MANNER WITHOUT THE PRIOR WRITTEN CONSENT OF DONGGUAN TIANDU ELECTRONICS CO., LTD		DESCRIPTIONS OF REVISION		APPD.
WITHIN 1.5mm : ±0.1mm						
OVER 1.5mm : ±0.2mm						
TITLE : HORIZONTAL SLIDE SWITCH			UNIT : mm	DRWG NO.: CMTDDZ-T3-243001-00		
MODEL: T3-243001-G			SCALE: 3:1	DWN.	ERIC	2013-6-17
CMTDDZ 东莞市田都电子有限公司 DONGGUAN TIANDU ELECTRONICS CO.,LTD.			CHK'D		MAIKO	2013-6-17
			APPD.		Coco	2013-6-17