

CAD FILE:

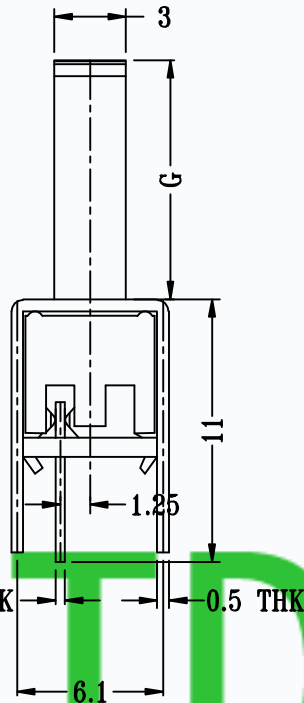

MODEL NO.	KNOB(G/VG)
T2-134001-G	(2~15)mm

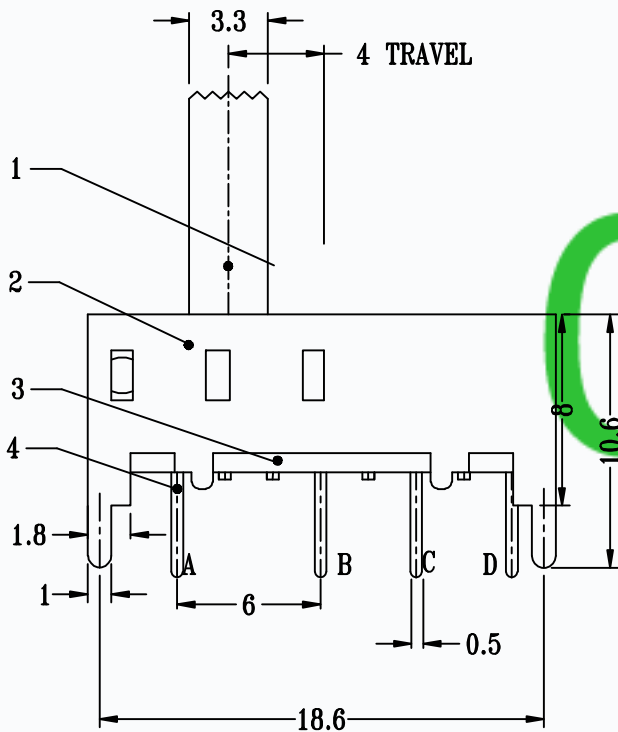
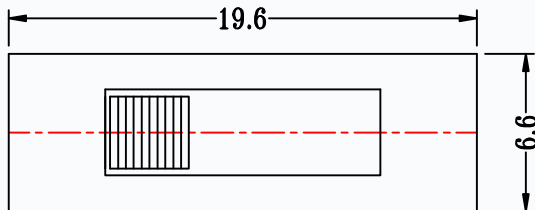
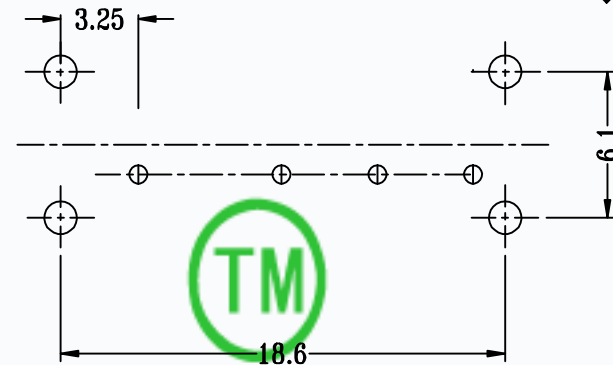

P.C.B. LAYOUT

A ↔ C: NON-SHORTING  
C ↔ D: SHORTING

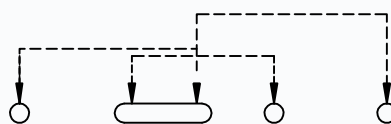

SCHEMATIC (NON-SHORTING AND SHORTING)

SPECIFICATIONS

Rating	0.3A 50V DC
CIRCUIT	1P3T
Timing	NON-SHORTING AND SHORTING
Travel	4.0mm
Contact Resistance	< 100 mΩ
Operating Force	250gf ± 100gf
Operating Life	10,000 cycles

NO.	PARTS	MATERIALS	Q'TY	FINISH
8				
7	STEEL BALL	STEEL	1	NATURAL
6	SPRING	STEEL WIRE	1	NATURAL
5	CONTACT CLIP	PBS STRIP	1	Ag PLATED
4	TERMINAL	BRASS STRIP	4	Ag PLATED
3	BASE	PHENOLIC RESIN	1	NATURAL
2	FRAME	STEEL STRIP	1	NI PLATED
1	KNOB	POM	1	BLACK

TOLERANCE UNLESS SPECIFIED	THESE DRAWINGS AND SPECIFICATIONS ARE THE PROPERTY OF DONGGUAN TIANDU ELECTRONICS CO.,LTD. AND SHALL NOT BE REPRODUCED, COPIED OR USED IN ANY MANNER WITHOUT THE PRIOR WRITTEN CONSENT OF DONGGUAN TIANDU ELECTRONICS CO., LTD	DESCRIPTIONS OF REVISION	APPD.
WITHIN 1.5mm : ±0.1mm OVER 1.5mm : ±0.2mm			
TITLE : VERTICAL SLIDE SWITCH	UNIT : mm	DRWG NO.: CMTDDZ-T2-134001-00	
MODEL: T2-134001-G	SCALE: 3:1	DWN.	ERIC 2013-6-17
CMTDDZ 东莞市田都电子有限公司 DONGGUAN TIANDU ELECTRONICS CO.,LTD.		CHK'D	MAIKO 2013-6-17
		APPD.	Coco 2013-6-17