

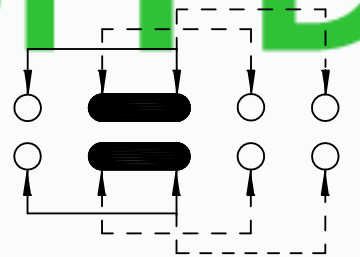

CAD FILE:

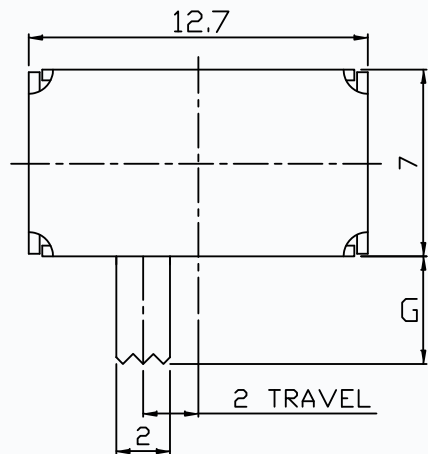
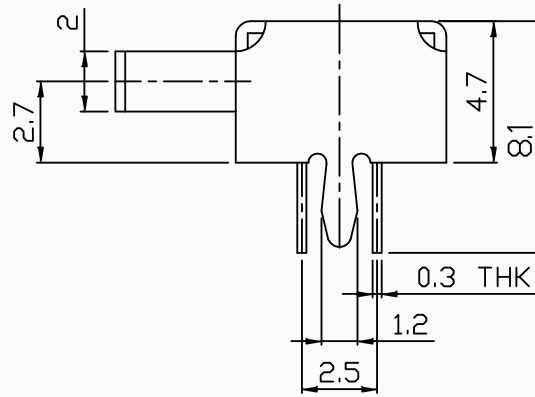
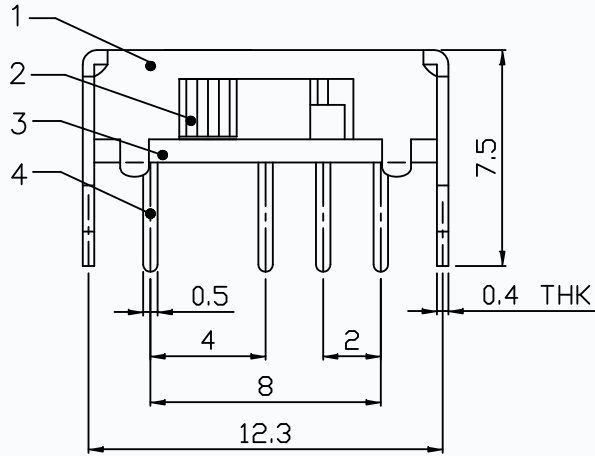

SCHEMATIC (NON-SHORTING)

MODEL NO.	KNOB(G/VG)
T3-232007-G	(2~9)mm

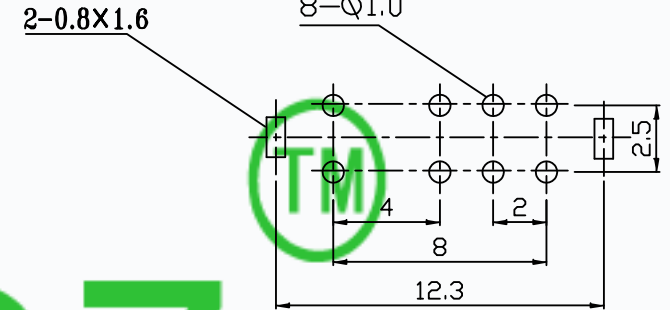
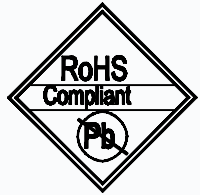

P.C.B. LAYOUT

CMTDDZ

SPECIFICATIONS

Rating	0.3A 50V DC
CIRCUIT	2P3T
Timing	NON-SHORTING
Travel	2.0mm
Contact Resistance	< 100 mΩ
Operating Force	250gf ± 100gf
Operating Life	10,000 cycles

8				
7				
6	SPRING PLATE	PBS STRIP	1	NATURAL
5	CONTACT CLIP	PBS STRIP	2	Ag PLATED
4	TERMINAL	BRASS STRIP	8	Ag PLATED
3	BASE	PHENOLIC RESIN	1	NATURAL
2	KNOB	POM	1	BLACK
1	FRAME	STEEL STRIP	1	NI PLATED
NO.	PARTS	MATERIALS	Q'TY	FINISH

TOLERANCE UNLESS SPECIFIED		THESE DRAWINGS AND SPECIFICATIONS ARE THE PROPERTY OF DONGGUAN TIANDU ELECTRONICS CO.,LTD. AND SHALL NOT BE REPRODUCED, COPIED OR USED IN ANY MANNER WITHOUT THE PRIOR WRITTEN CONSENT OF DONGGUAN TIANDU ELECTRONICS CO., LTD		DESCRIPTIONS OF REVISION		APPD.
WITHIN 1.5mm : ±0.1mm		OVER 1.5mm : ±0.2mm		TITLE : HORIZONTAL SLIDE SWITCH		UNIT : mm
				DRWG NO.: CMTDDZ-T3-232007-00		
MODEL: T3-232007-G		SCALE: 3:1		DWN.	ERIC	2013-6-17
CMTDDZ 东莞市田都电子有限公司		DONGGUAN TIANDU ELECTRONICS CO.,LTD.		CHK'D	MAIKO	2013-6-17
				APPD.	Coco	2013-6-17