

CAD FILE:

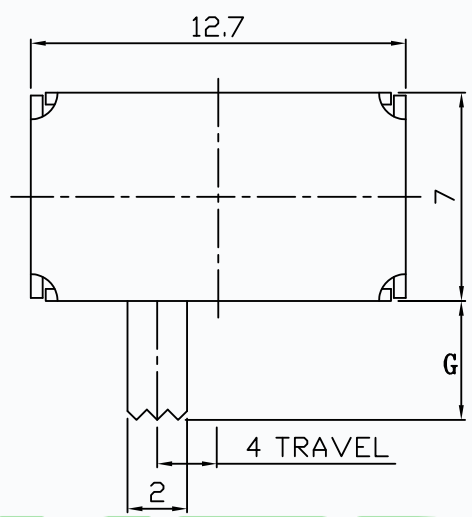

MODEL NO.	KNOB(G/VG)
T3-224007-G	(2~8)mm

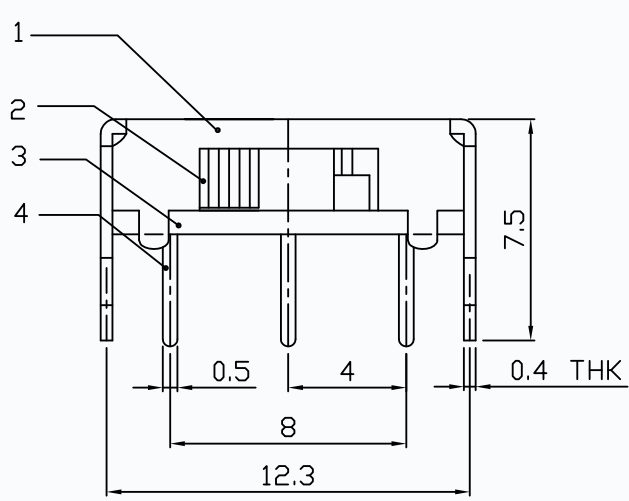
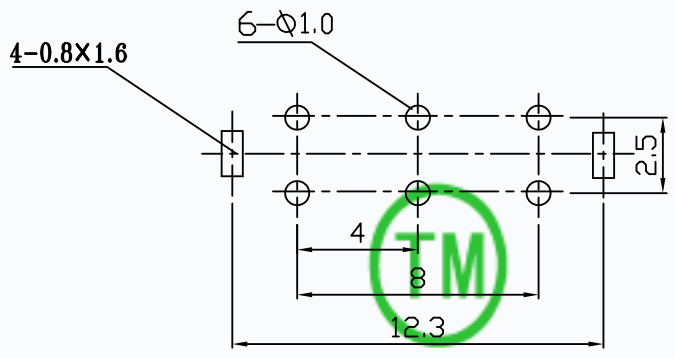

P.C.B. LAYOUT

**CMTDDZ**

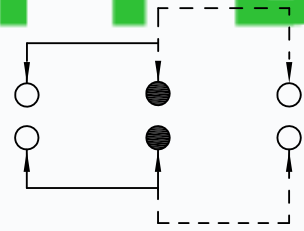
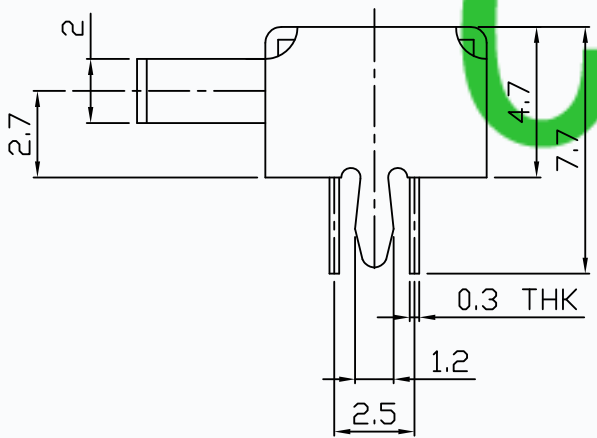

SCHMATIC (NON-SHORTING)

SPECIFICATIONS

Rating	0.3A 50V DC
CIRCUIT	2P2T
Timing	NON-SHORTING
Travel	4.0mm
Contact Resistance	< 100 mΩ
Operating Force	250gf ± 100gf
Operating Life	10,000 cycles

NO.	PARTS	MATERIALS	Q'TY	FINISH
8				
7				
6	SPRING PLATE	PBS STRIP	1	NATURAL
5	CONTACT CLIP	PBS STRIP	2	Ag PLATED
4	TERMINAL	BRASS STRIP	6	Ag PLATED
3	BASE	PHENOLIC RESIN	1	NATURAL
2	KNOB	POM	1	BLACK
1	FRAME	STEEL STRIP	1	NI PLATED

TOLERANCE UNLESS SPECIFIED	THESE DRAWINGS AND SPECIFICATIONS ARE THE PROPERTY OF DONGGUAN TIANDU ELECTRONICS CO.,LTD. AND SHALL NOT BE REPRODUCED, COPIED OR USED IN ANY MANNER WITHOUT THE PRIOR WRITTEN CONSENT OF DONGGUAN TIANDU ELECTRONICS CO., LTD	DESCRIPTIONS OF REVISION	APPD.
WITHIN 1.5mm : ±0.1mm			
OVER 1.5mm : ±0.2mm			
TITLE : HORIZONTAL SLIDE SWITCH		UNIT : mm	DRWG NO.: CMTDDZ-T3-224007-00
MODEL: T3-224007-G		SCALE: 3:1	DWN. ERIC 2013-6-17
CMTDDZ 东莞市田都电子有限公司 DONGGUAN TIANDU ELECTRONICS CO.,LTD.		CHK'D	MAIKO 2013-6-17
		APPD.	Coco 2013-6-17